

**ATM-M Series**  
**5 DIGIT DUAL INPUT MICRO**  
**PROCESSOR**  
**MATH FUNCTION ISOLATED**  
**TRANSMITTER**

**USER'S MANUAL (V1.1)**

**健昇科技股份有限公司**

**JS AUTOMATION CORP.**

新北市汐止區中興路 100 號 6 樓  
6F., No.100, Zhongxing Rd.,  
Xizhi Dist., New Taipei City, Taiwan  
TEL : +886-2-2647-6936  
FAX : +886-2-2647-6940  
<http://www.automation.com.tw>  
<http://www.automation-js.com/>  
E-mail : [control.cards@automation.com.tw](mailto:control.cards@automation.com.tw)

## Correction record

Version	Record
V1.1	Modify 10. Ordering information

# Contents

1. Features.....	3
2. Specifications.....	3
3. Front panel & Key functions .....	4
4. General Mode Operating Procedures.....	5
5. Programming Mode Operating Procedures .....	6
6. Error Code of Self-Diagnosis .....	7
7. Calibration Operating Procedures.....	8
8. Dimensions .....	8
9. Wiring Connection.....	9
10. Ordering information .....	9

## 1. Features

- Versatile Input selection : 0~50mV , 0~10V , 0~300V , 0~200mA , 4~20mA
- Versatile output selection : 4~20mA , 0~20mA , 0~5V , 0~10V
- Accuracy :  $\pm 0.1\%$  F.S.
- Mathematic function (  $A \pm B$  ,  $A \times B$  ,  $A/B$  ,  $A \& B$  (Hi or Lo) ,  $|A|$  ,  $\sqrt{A}$  )
- General input & output selectable
- Surge test of AC 2000V/1min between input / output / power

## 2. Specifications

- Input selection : 0~50mV , 0~10V , 0~300V , 0~200mA , 4~20mA
- Output selection : 4~20mA , 0~20mA , 0~5V , 0~10V
- Accuracy :  $\pm 0.1\%$  F.S.
- Display Screen : High brightness red LED; 10.16mm(0.4")
- Display Range : -19999~99999
- Zero Adjustment :  $\pm 9999$
- Span Adjustment :  $\pm 9999$
- Parameters Setting : Push buttons
- Back Up Memory : EEPROM
- Over Range Indication : doFL/ioFL or -doFL/-ioFL
- Analog Output Resolution : 15 bit
- Output Ripple :  $\leq \pm 0.1\%$  F.S.
- Output Response Time : < 250 msec (0~90%)
- Output Capability : Voltage Output: < 20mA  
Current Output: < 10V
- Isolation : Input / Output / Power / Case
- Insulation Resistance : > 100M $\Omega$  with 500Vdc
- Surge Test : 2KVac/1min
- Input Impedence : Voltage: > 2V for 20K $\Omega$ /V;  $\leq 2V$  for > 200M $\Omega$   
Current:  $\geq 0.2A$  at 100mV; < 0.2A at 1V
- Temperature Coefficient : 100ppm/degree C (0~60 degree C )
- Operating Temperature : 0-60 degree C
- Operating Humidity : 20 to 90% RH (non-condensing)
- Storage Temperature : -10-70 degree C
- Storage Humidity : 20 to 90% RH (non-condensing)
- Power Supply : AC 110, AC 220V
- Installation : Socket / Plug-in

### 3. Front panel & Key functions

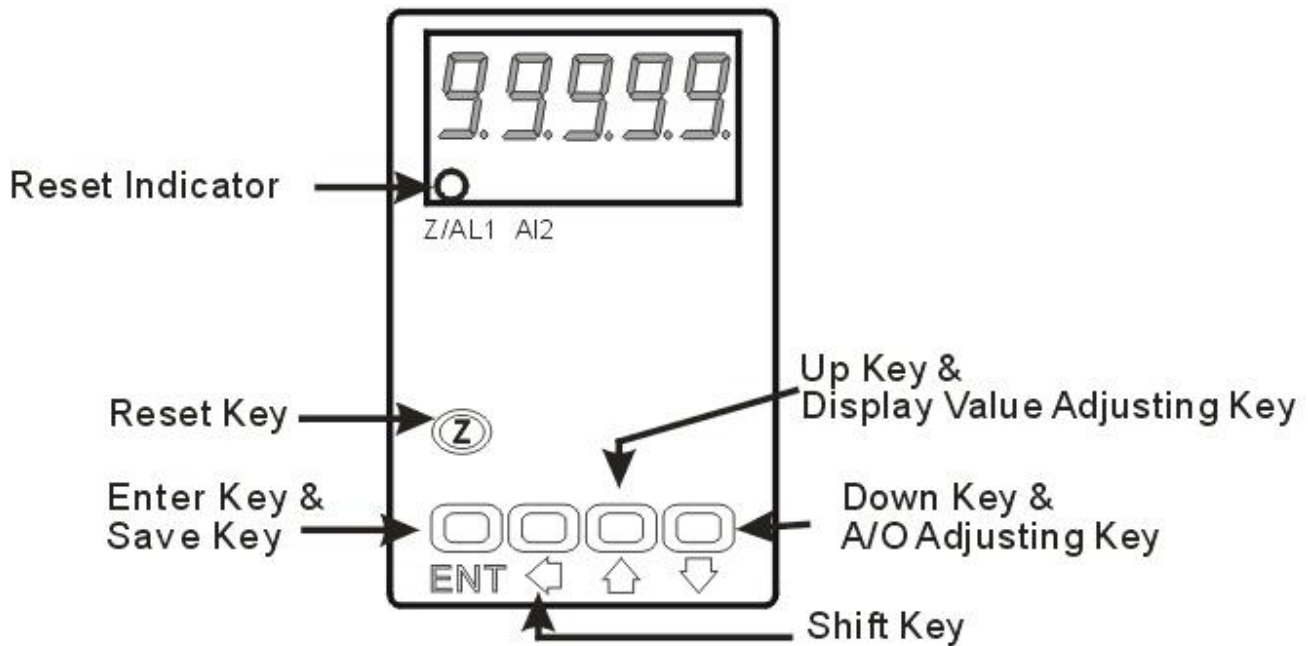

Key Name	Symbol	Descriptions
Reset Key	<b>Z</b>	1. Press this key to enable the reset function & reset indicator (Z) is light; press this key again to disable the reset function & reset indicator (Z) is dark.
Enter Key & Save Key	<b>ENT</b>	1. In the measuring status, press this key can enter to parameter pages. 2. In the parameter setting, press this key can save the value & go to next parameter.
Shift Key	⇐	1. In the parameter setting, press this key can move the cursor left.
Up Key & Display Value Adjusting Key	↑	1. In the measuring status, press this key for 3 sec can enter to display adjustment of "ZERO" & "SPAN" 2. In the parameter setting, press this key can increase the digits.
Down Key & A/O Adjusting Key	↓	1. In the measuring status, press this key for 3 sec can enter to analog output adjustment. 2. In the parameter setting, press this key can decrease the digits.

1. The following block charts are parameters codes, parameter codes & parameters will alternate flashing if the parameters can be modified.
2. To modify the parameters, please press ⇐ ↑ ↓, and press ENT to save the parameters after the modification.
3. Please don't forget the new pass code after modification.
4. In any pages, pres ↑ & ↓, or don't press any keys for 2 minutes that will back to measuring status.

## 4. General Mode Operating Procedures











Block Charts	Display	Descriptions	Default	
		<b>Display : "ZERO" &amp; "SPAN" Adjustment</b>		
	Measuring Status	Present value for measurement.		
	Display (dZEro)	Press ⇐ to select adjusting speed rate, press ↑ ↓ to modify the zero value.	00000	
	Adjustment (dZEro)	PS: To use this function to adjust the real zero value.		
	Display Span Adjustment (dSPAN)	Press ⇐ to select adjusting speed rate, press ↑ ↓ to modify the span value.	00000	
			<b>Analog Output: "ZERO" &amp; "SPAN" Adjustment</b>	
	Measuring Status	Present value for measurement.		
A/O Zero Adjustment (AZEro)	Press ⇐ to select adjusting speed rate, press ↑ ↓ to modify the A/O zero.	00000		
A/O Span Adjustment (ASPA)	Press ⇐ to select adjusting speed rate, press ↑ ↓ to modify the A/O span.	00000		
		<b>Display Value: Preview Input A &amp; Input B</b>		
	Measuring Status	Present value for measurement.		
	Preview Input A Display Value (A CH.)	press ↑ ↓ to show the current input A display value	Input A Display Value	
	Preview Input B Display Value (B CH.)	press ↑ ↓ to show the current input B display value	Input B Display Value	

## 5. Programming Mode Operating Procedures

Block Charts	Display	Descriptions	Default
	Measuring Status	Present value for measurement.	
	Pass Code (P.Cod)	Press $\leftarrow$ $\uparrow$ $\downarrow$ to enter pass code.	<b>00000</b>
	Math Type Setting (tYPE)	Pass $\uparrow$ $\downarrow$ to select the math type of input A & input B; A (Sqr. $\sqrt{A}$ ), $ A $ (Abs.A), A+B (Add.Ab), A-B (Sub.Ab), AXB (MUL.Ab), A/B (div.Ab), A&BHi (And.Hi), A&BLo (And.Lo).	<b>59-r</b>
	Decimal Point Setting (dP)	Pass $\uparrow$ $\downarrow$ to select decimal point (0, 1, 2, 3, 4). EX: if the value shows "0.00" that means the decimal point is 2 digits.	<b>00000</b>
	Input A Display Low Scale (AdSPL) Setting	Pass $\leftarrow$ $\uparrow$ $\downarrow$ to modify display low scale for the input signal zero value. EX: If the input signal is 4~20mA; 4mA is shown display 0.00, this parameter must be set for 000.00.	Customers specify
	Input A Display Hi Scale Setting (AdSPH)	Pass $\leftarrow$ $\uparrow$ $\downarrow$ to modify display high scale for the input signal span value. EX: If the input signal is 4~20mA; 20mA is shown display 100.00, this parameter must be set for 100.00.	Customers specify
	Input B Display Low Scale (BdSPL) Setting	Pass $\leftarrow$ $\uparrow$ $\downarrow$ to modify display low scale for the input signal zero value. EX: If the input signal is 4~20mA; 4mA is shown display 0.00, this parameter must be set for 000.00.	Customers specify
	Input B Display Hi Scale Setting (BdSPH)	Pass $\leftarrow$ $\uparrow$ $\downarrow$ to modify display high scale for the input signal span value. EX: If the input signal is 4~20mA; 20mA is shown display 100.00, this parameter must be set for 100.00.	Customers specify
	Display Average Setting (AvG)	Pass $\leftarrow$ $\uparrow$ $\downarrow$ to modify display average (1~99). PS: Please use this function for stable display value when input signal is unstable.	<b>00005</b>
	Display Low Cut Setting (LCUt)	Pass $\leftarrow$ $\uparrow$ $\downarrow$ to modify display low cut to 0 (0~99).	<b>00000</b>
	A/O Polarity Setting (PoLAr)	Pass $\leftarrow$ $\uparrow$ $\downarrow$ to modify output is positive pole or negative pole. PS : Voltage output ,NO: positive pole output (0~+10V) YES: positive & negative pole output (-10~+10V)	<b>no</b>

A/O Low Scale Setting (AnLo)	Pass ⇐ ↑ ↓ to adjust A/O low scale to correspond to the display value. EX : A/O is 0~10V, the display is 10.0 to output 0V, this value must be set for 10.0.	00000
A/O Hi Scale Setting (AnHi)	Pass ⇐ ↑ ↓ to adjust A/O hi scale to correspond to the display value. EX : A/O is 0~10V, the display is 90.0 to output 1 0V, this value must be set for 90.0.	99999
Pass Code Setting (CodE)	Pass ⇐ ↑ ↓ to modify pass code (0~19999). PS: Please don't forget the new pass code after modification.	00000
Key Lock Setting (LoCK)	Pass ↑ ↓ to lock the keys, using key lock function only can view the parameters, but cannot modify any values. PS: no (unlock) ,YES ("ENT" unlock , others lock).	no

## 6. Error Code of Self-Diagnosis

Display	Descriptions
	Input signal is over 120% of input range.
	Input signal is under -20% of input range.
	Input signal A is over display range (19999).
	Input signal A is under display range (-19999).
	Input signal is over 180% of input range or meter error.
	Math operating result is over display range (19999).
	Math operating result is under display range (-19999).
	Input signal B is over display range (19999).
	Input signal B is under display range (-19999).
	EEPROM reading/writing suffers the interference (about 1 million times).

※Please check the wiring connection is correct first, if the problem still exist, please return the meter to the factory.



## 7. Calibration Operating Procedures

	Display	Descriptions	Default
	Measuring Status	Present value for measurement Press ENT & ← together for 3 sec will enter to calibration operating procedures.	
	Input Low Scale 1 Calibration (inLo1)	1. Input standard low scale signal to input 1. 2. Press ← ↑ ↓ to calibrate input low scale.	
	Input Hi Scale 1 Calibration (inHi 1)	1. Input standard hi scale signal to input 1. 2. Press ← ↑ ↓ to calibrate input hi scale	
	Input Low Scale 2 Calibration (inLo2)	1. Input standard low scale signal to input 2. 2. Press ← ↑ ↓ to calibrate input low scale.	
	Input Hi Scale 2 Calibration (inHi 2)	1. Input standard hi scale signal to input 2. 2. Press ← ↑ ↓ to calibrate input hi scale	
	System Setting Page (SYS)	1. Finish calibration operating procedures will enter to system setting group. 2. Press ↑ & ↓ together to back to measuring status.	

Warning: Calibration of this meter requires a standard signal with 0.01% accuracy or better and an external meter with 0.005% accuracy or better.

## 8. Dimensions

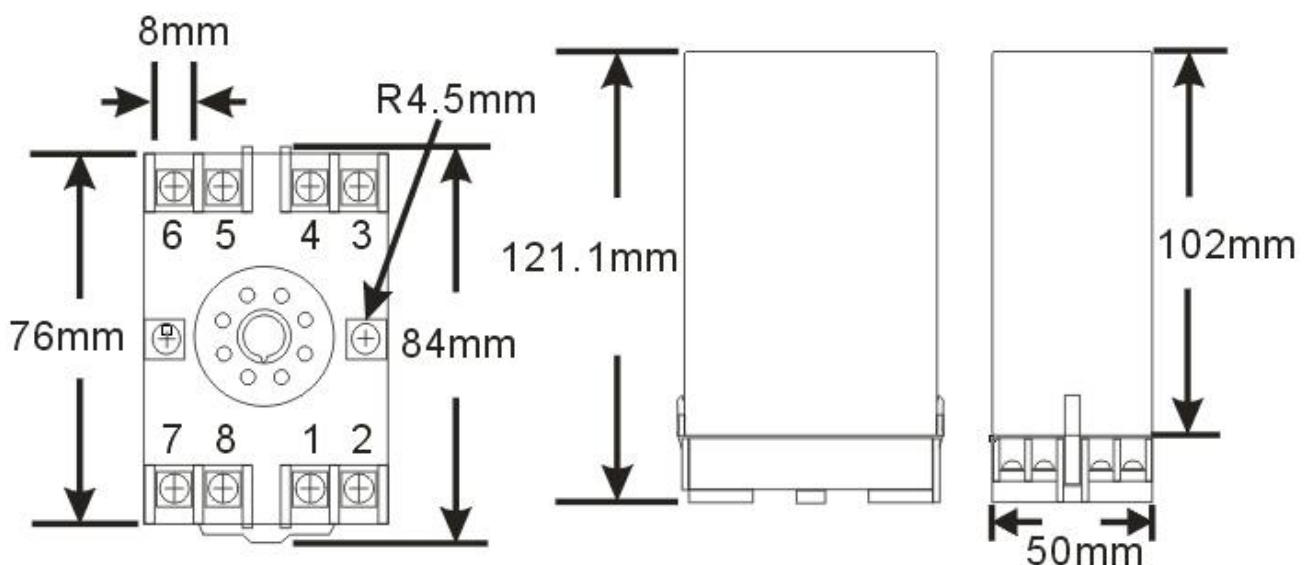

## 9. Wiring Connection

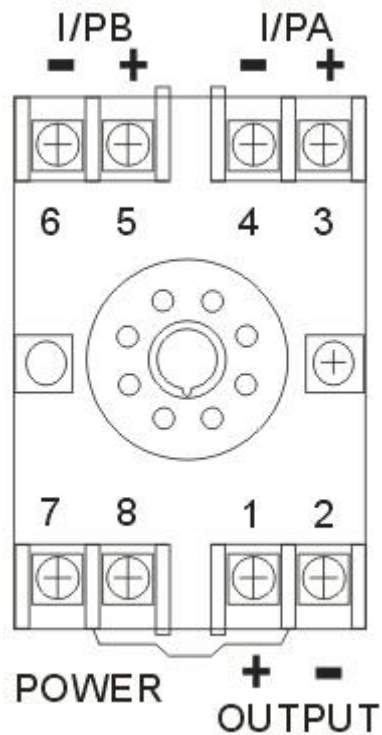

## 10. Ordering information

