

DIO3217
Multifunction timer/counter
Digital I/O Card

User's Manual (V1.2)

健昇科技股份有限公司

JS AUTOMATION CORP.

新北市汐止區中興路 100 號 6 樓
6F., No.100, Zhongxing Rd.,
Xizhi Dist., New Taipei City, Taiwan
TEL : +886-2-2647-6936
FAX : +886-2-2647-6940
<http://www.automation.com.tw>
<http://www.automation-js.com/>
E-mail : control.cards@automation.com.tw

Correction record

Version	Record
V1.0->V1.1	Modify 6. I/O interface diagram
V1.1->V1.2	Modify 2. Feature-Delete Software key function

Contents

1. Forward.....	4
2. Features.....	5
2.1 Main card.....	5
2.2 Din rail mounted wiring board.....	5
3. Specifications.....	6
3.1 DIO3217 Main card.....	6
3.2 Din rail mounted wiring board.....	8
4. Layout and dimensions.....	10
4.1 DIO3217 Main card.....	10
4.2 ADP3217DIN Din rail mounted wiring board.....	10
4.3 ADP9201DIN Din rail mounted wiring board.....	11
4.4 JS51053 for ADP9201_JM1/ ADP9201_JM2 20PM Din rail mounted dummy wiring board.....	11
5. PIN definitions.....	12
5.1 Pin definitions for ADP9201_JM1 connector.....	12
5.2 Pin definitions for ADP9201_JM2 connector.....	12
6. I/O interface diagram.....	13
6.1 Input diagram.....	13
6.2 Output diagram.....	14
7. Hardware settings.....	16
7.1 CARD ID setting.....	16
7.2 Jumper setting.....	16
8. Applications.....	17
9. Ordering information.....	18

Notes on hardware installation

Please follow step by step as you are installing the control cards.

1. Be sure your system is power off.
2. Be sure your external power supply for the wiring board is power off.
3. Plug your control card in slot, and make sure the golden fingers are put in right contacts.
4. Fasten the screw to fix the card.
5. Connect the cable between the card and wiring board.
6. Connect the external power supply for the wiring board.
7. Recheck everything is OK before system power on.
8. External power on.

Congratulation! You have it.

For more detail of step by step installation guide, please refer the file “installation.pdf” on the CD come with the product or register as a member of our user’s club at:

<http://automation.com.tw/>

to download the complementary documents.

Warning:

Some computer BIOS has “Auto detect DIMM/PCI clock” option, be sure to switch to “DISABLE” else in some cases the PCI add on cards will not be detected by windows at cold start.

1. **Forward**

Thank you for your selection of JAC's product DIO3217 , a multifunction timer /counter DIGITAL I/O card for industrial PC. In the field of industrial control, digital I/O is generally controlled under a microprocessor and owing to their specific consideration of industrial environment, it is quite different from the laboratory requirement. Except for the digital I/O's, the powerful timer counter function provide high speed counting and programmable trigger output and quadrature encoder counting mode.

Our experience in the noise immunity makes this card very stable in the noisy environment and you don't worry about computer hanged by external noise. We wish the card that will be helpful to your project.

Other DIO series products:

- DIO9201 16 channel input and 16 channel output isolated digital I/O card (ISA bus)
- DIO2232 32 channel input and 32 channel output isolated digital I/O card (ISA bus)
- DIO2248 48 channel input and 16 channel output isolated digital I/O card (ISA bus)
- DIO2264 64 channel input isolated digital I/O card (ISA bus)
- DIO3206 48 channel TTL digital I/O Card (PCI bus)
- DIO3208B 8 channel input and 8 channel relay output isolated digital I/O card (PCI bus)
- DIO3216B 16 channel input and 16 channel relay output isolated digital I/O card (PCI bus)
- DIO3232 32 channel input and 32 channel output isolated digital I/O card (PCI bus)
- DIO3248 48 channel input and 16 channel output isolated digital I/O card (PCI bus)
- DIO3264 64 channel input isolated digital I/O card (PCI bus)
- DIO4264 64 TTL digital I/O PC-104 Module
- DIO6208 8 channel input and 8 channel relay output isolated digital I/O PCI-104 Module
- DIO6216 16 channel input and 16 channel relay output isolated digital I/O PCI-104 Module

Any comment is welcome,

please visit our website

<http://www.automation.com.tw/>

<http://www.automation-js.com/> for the up to date information.

2. Features

2.1 Main card

- 2.1.1 16 isolated DI and 16 isolated DO channels
- 2.1.2 High voltage isolation on all isolated channel (2500 Vac)
- 2.1.3 Programmable digital filter at 100Hz, 200Hz, 1KHz and no de-bounce for input
- 2.1.4 No output transition during start-up
- 2.1.5 Output status read back
- 2.1.6 External triggered interrupt (on IN00~IN07)
- 2.1.7 Keep output state after hot reset (jumper selectable)
- 2.1.8 High speed timer counter function provides timer, counter and PWM function
 - Gate control
 - Counter input
 - Programmable trigger output
- 2.1.9 Quadrature counter function

2.2 Din rail mounted wiring board

- 2.2.1 ADP3217DIN Din rail mounted wiring board
- 2.2.2 ADP9201DIN Din rail mounted wiring board
- 2.2.3 JS51053 20P Din rail mounted dummy wiring board

3. **Specifications**

3.1 DIO3217 Main card

Input Section

- 3.1.1 Input : 14 photo-isolated ,
2 high speed magnetic coupler (TTL level)
- 3.1.2 ON state : 2.8Vdc(max) 4.5mA(min)
- 3.1.3 OFF state : 8Vdc(min) 3mA(max)
- 3.1.4 Switching speed : 10KHz max. (limit by photo coupler speed and debounce filter)
- 3.1.5 Interrupt at IN00 ~ IN07

Output Section

- 3.1.6 Output : 14 photo-isolated,
2 high speed magnetic coupler (open collector)
- 3.1.7 Output range : Open collector 0 ~ 45 Vdc (on card)
- 3.1.8 Output rating : 3A @250Vac, 30Vdc (Relay)
1A @ 24Vdc (PMOS)
2A @ 240Vac (SSR)
- 3.1.9 Sink current : 500mA(peak) per channel (on card)
- 3.1.10 Switching speed : 20KHz(max)(MOS out only)

Timer/ counter/ PWM section

- 3.1.11 Timer time base: 1us
- 3.1.12 Timer/counter length:32 bit
- 3.1.13 Counter frequency (max) : 8MHz
- 3.1.14 PWM time base: 33MHz
- 3.1.15 PWM frequency: 16 bit
- 3.1.16 PWM duty: 16 bit

Quadrature counter

3.1.17 Quadrature input frequency(max): 8MHz

3.1.18 Input mode: A,B phase (quadrature mode)

3.1.19 Counter length: 32 bit

Main Card General

3.1.20 Card ID : 4 bits

3.1.21 Insulation resistance : 100M Ohm (min) at 1000Vdc

3.1.22 Isolation voltage : 2500Vac 1Min

3.1.23 Connector : Two 20-pin male flat-cable connectors

3.1.24 Operation temperature : 0 to +70 degree C

3.1.25 Storage temperature : -20 to +80 degree C

3.1.26 Operation humidity : 5~95% RH, non-condensing

3.1.27 Dimensions : 130(W) * 102(H) mm , 5.2(W) * 4.1(H)in

3.2 Din rail mounted wiring board

ADP3217DIN Din rail mounted wiring board

- 3.2.1 External Supply : DC 24V \pm 4V
- 3.2.2 Input : 6 with LED indicator, 2 specific timer/counter input
- 3.2.3 Output : ADP3217DIN(R) : 6 relays (3A @250Vac, 3A @30Vdc) with LED indicator ,
2 high speed isolated open collector output
ADP3217DIN(S) : 6 SSR (2A @240Vac) with LED indicator,
2 high speed isolated open collector output
ADP3217DIN(P) : 6 PMOS (Source 1A @24Vdc) with LED indicator,
2 high speed isolated open collector output
- 3.2.4 Connector: One 20-pin male flat-cable connector
- 3.2.5 Operation Temperature: 0 to +70 degree C
- 3.2.6 Operation Humidity: RH5~95%, non-condensing
- 3.2.7 Dimension: ADP3217DIN(R) / (P) : 86(W) * 103(L) *45(H)mm;
3.4(W)*4.1(L)*1.8(H)in
ADP3217DIN(S) : 86(W) * 103(L) *50(H)mm
3.4(W)*4.1(L)*2.0(H)in

ADP9201DIN Din rail mounted wiring board

- 3.2.8 External Supply : DC 24V \pm 4V
- 3.2.9 Input : 8 with LED indicator
- 3.2.10 Output : ADP9201DIN(R) : 8 relays (3A @250Vac, 3A @30Vdc) with LED indicator
ADP9201DIN(S) : 8 SSR (2A @240Vac) with LED indicator
ADP9201DIN(P) : 8 PMOS (Source 1A @24Vdc) with LED indicator
- 3.2.11 Connector: One 20-pin male flat-cable connector
- 3.2.12 Operation Temperature: 0 to +70 degree C
- 3.2.13 Operation Humidity: RH5~95%, non-condensing

3.2.14 Dimension: ADP9201DIN(R) / (P) : 86(W) * 103(L) *45(H)mm;
3.4(W)*4.1(L)*1.8(H)in
ADP9201DIN(S) : 86(W) * 103(L) *50(H)mm
3.4(W)*4.1(L)*2.0(H)in

JS51053 20PM Din rail mounted dummy wiring board

3.2.15 Dimension: 86(W)*79(L)*52(H)mm, 3.4(W)*3.2(L)*2.1(H)in

4. Layout and dimensions

4.1 DIO3217 Main card

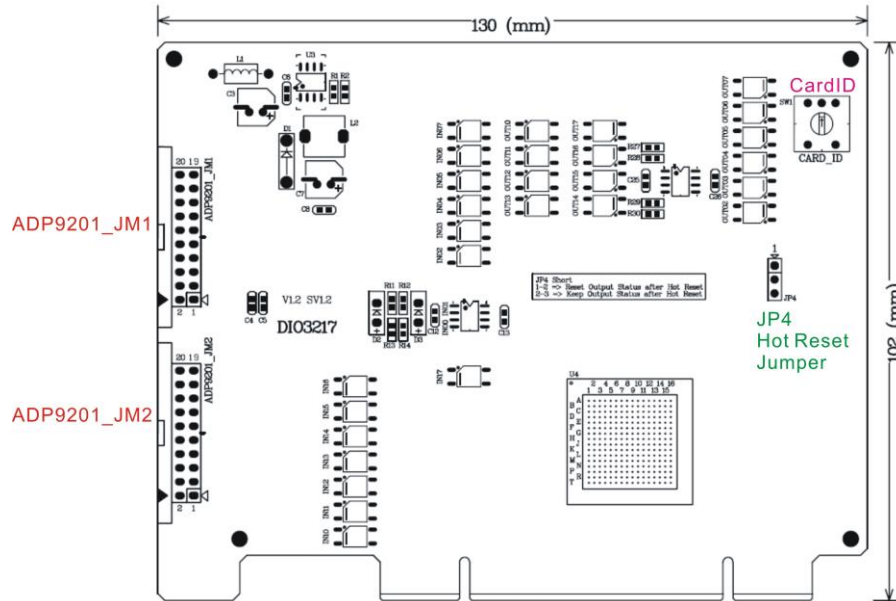

4.2 ADP3217DIN Din rail mounted wiring board

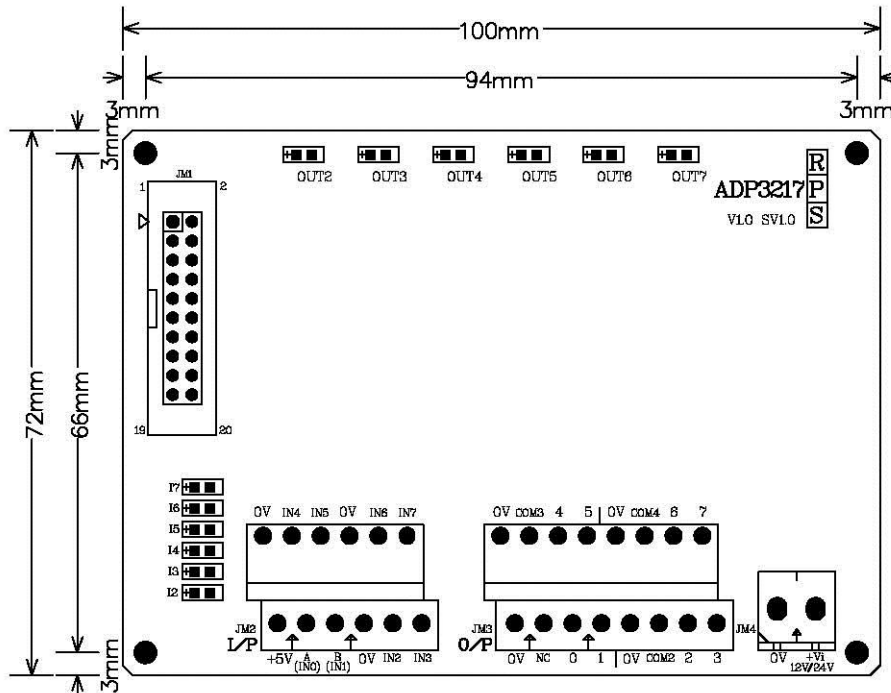

4.3 ADP9201DIN Din rail mounted wiring board

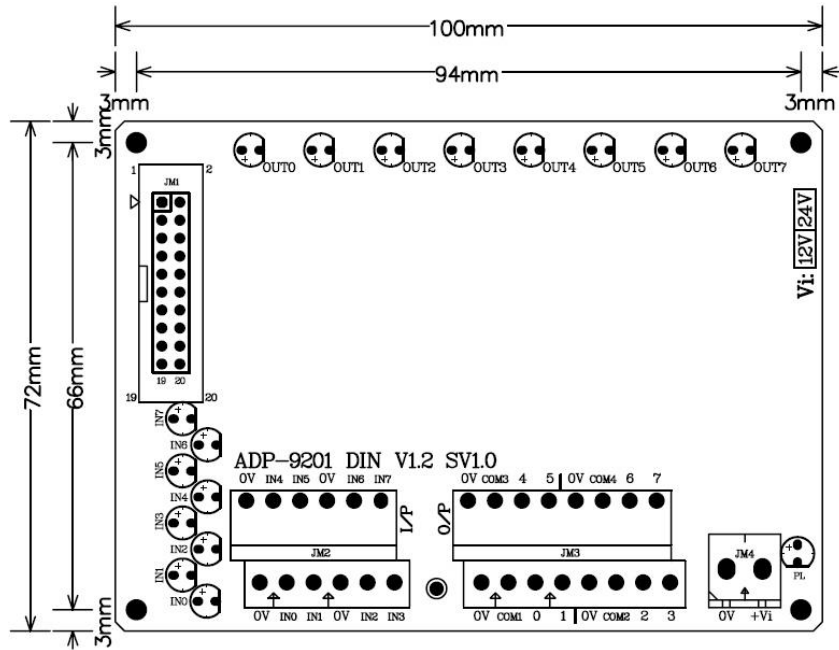

4.4 JS51053 for ADP9201_JM1/ ADP9201_JM2 20PM Din rail mounted dummy wiring board

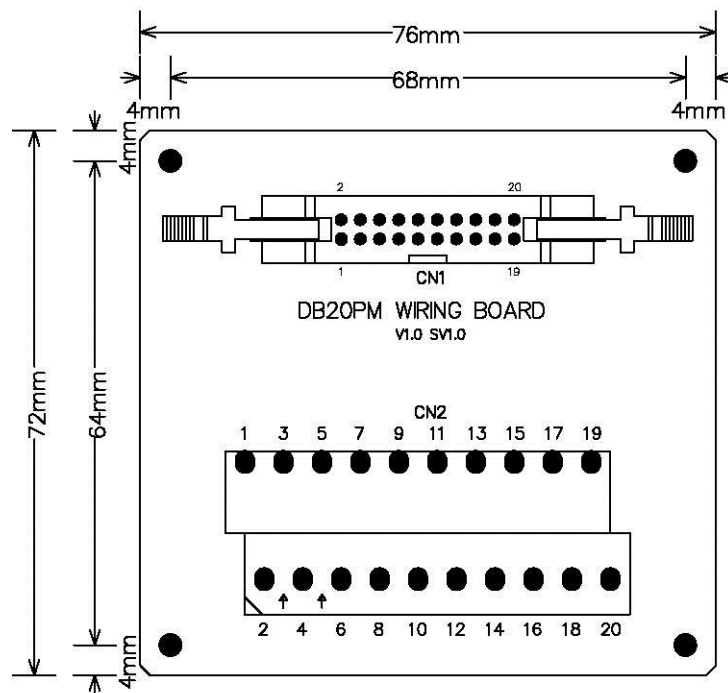

5. PIN definitions

5.1 Pin definitions for ADP9201_JM1 connector

PIN	Descriptions		PIN	Descriptions
1	EXT_IN00 Ti (counter input) (High speed in)	EXT_IN00	2	EXT_OUT00/ TOUT (High speed out)
3	EXT_IN01 GATE (High speed in)	EXT_IN01	4	EXT_OUT01 (High speed out)
5	EXT_IN02	EXT_IN02	6	EXT_OUT02
7	EXT_IN03	EXT_IN03	8	EXT_OUT03
9	EXT_IN04	EXT_IN04	10	EXT_OUT04
11	EXT_IN05	EXT_IN05	12	EXT_OUT05
13	EXT_IN06	EXT_IN06	14	EXT_OUT06
15	EXT_IN07	EXT_IN07	16	EXT_OUT07
17	EXTG	EXTG	18	EXTG
19	+24Ve	EXT +24Vin	20	+24Ve

5.2 Pin definitions for ADP9201_JM2 connector

PIN	Descriptions		PIN	Descriptions
1	EXT_IN10	EXT_IN10	2	EXT_OUT10
3	EXT_IN11	EXT_IN11	4	EXT_OUT11
5	EXT_IN12	EXT_IN12	6	EXT_OUT12
7	EXT_IN13	EXT_IN13	8	EXT_OUT13
9	EXT_IN14	EXT_IN14	10	EXT_OUT14
11	EXT_IN15	EXT_IN15	12	EXT_OUT15
13	EXT_IN16	EXT_IN16	14	EXT_OUT16
15	EXT_IN17	EXT_IN17	16	EXT_OUT17
17	EXTG	EXTG	18	EXTG
19	+24Ve	EXT +24Vin	20	+24Ve

6. I/O interface diagram

6.1 Input diagram

Type 1 input : High speed

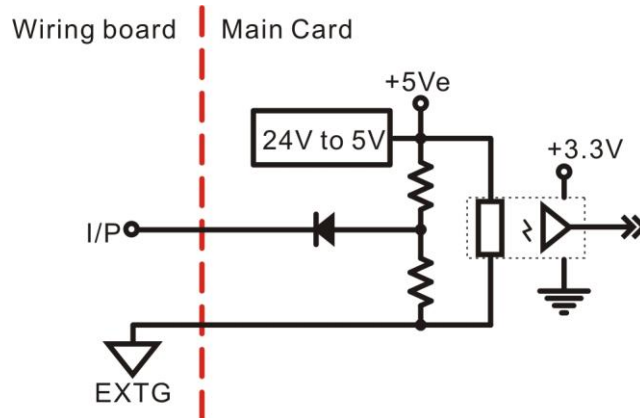

(Only for IN00,IN01 use ADP3217DIN wiring board)

Type 2 input :

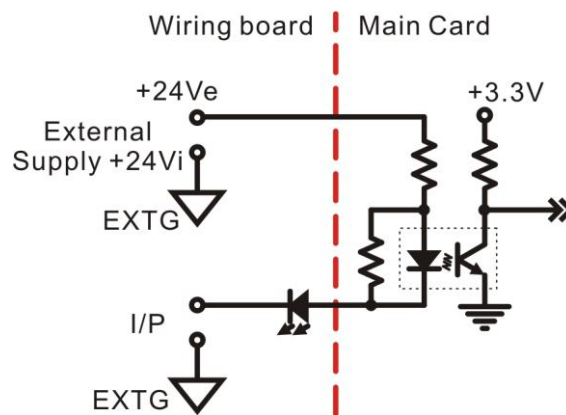

(Except for IN00,IN01)

6.2 Output diagram

Type 1 output : High speed

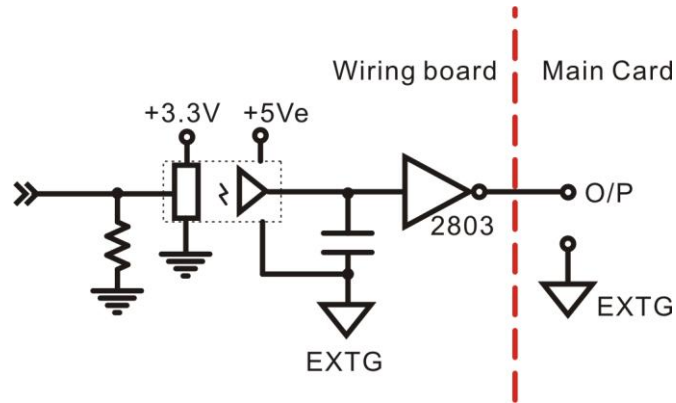

(Only for OUT00,OUT01 use ADP3217DIN wiring board)

Type 2 output : (PMOS)

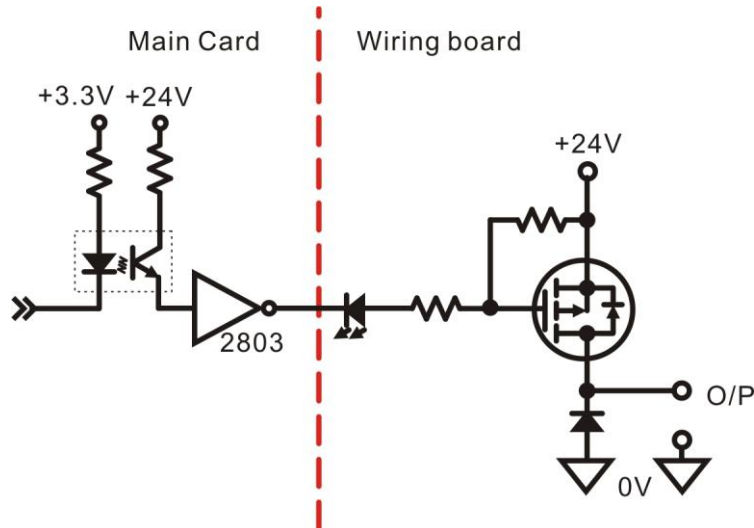

(Except for OUT00,OUT01)

Type 3 output : (Relay)

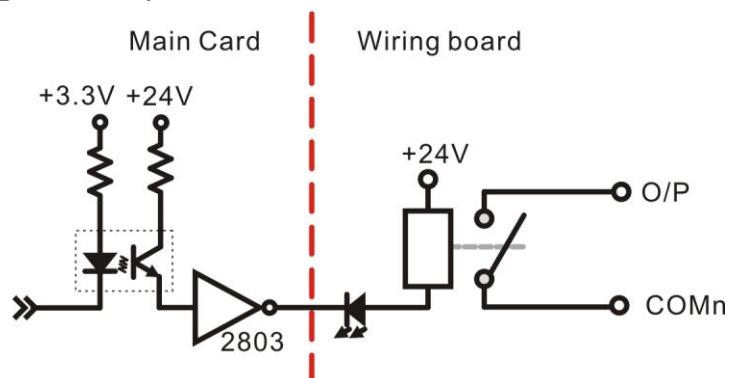

(Except for OUT00,OUT01)

Type 4 output : (SSR)

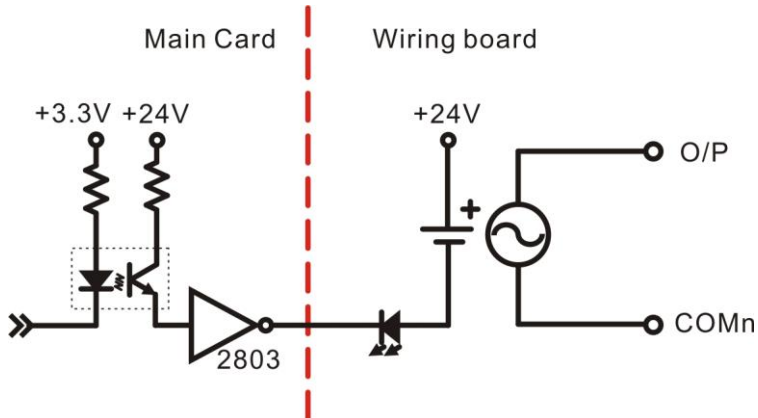

(Except for OUT00,OUT01)

7. Hardware settings

7.1 CARD ID setting

Since PCI cards have plug and play function, the card ID is required for programmer to identify which card he/she will control without knowing the physical address assigned by the Windows. A 4 bits DIP switch or rotary switch for distinguishing the 16 identical card.

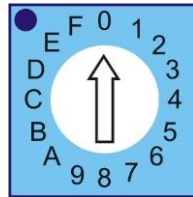

The following example sets the card ID at 12.

Example for card ID setting



Rotary switch set at ID=0

7.2 Jumper setting

Output relay contact type setting (JP4)	
	
Reset output after warm reset	Keep output after warm reset

8. Applications

- Accept : -- P.B./M.S./EMG./Contact- Start/Stop/Limit switch/sensor
 - Interlock/selective Sw.- Proximity switch
 - Aux. contact of transducer/detector
- As I/O of S/W PLC Controller
- Industrial ON/OFF control
- High speed counter
- Trigger event counter
- Quadrature encoder counter
- Up/down or pulse /direction counter
- PWM controller

9. Ordering information

<u>PRODUCT</u>	<u>DESCRIPTIONS</u>
DIO3217	32-channel Digital I/O Card for 16 DI and 16 DO Photo-coupler isolated with Multifunction timer/counter
ADP3217DIN (R)	DIN rail mounted wiring board with 12 I/O LED indicators, Relay output for 6 DI, 6DO and 2 high speed TTL input, 2 high speed open collector output
ADP3217DIN(S)	DIN rail mounted wiring board with 12 I/O LED indicators, SSR output for 6 DI, 6DO and 2 high speed TTL input, 2 high speed open collector output
ADP3217DIN(P)	DIN rail mounted wiring board with 12 I/O LED indicators, PMOS output for 6 DI, 6DO and 2 high speed TTL input, 2 high speed t open collector output
ADP9201DIN(R)	DIN rail mounted wiring board with 16 I/O LED indicators and relay output for 8 DI, 8DO
ADP9201DIN(S)	DIN rail mounted wiring board with 16 I/O LED indicators and SSR output for 8 DI, 8DO
ADP9201DIN(P)	DIN rail mounted wiring board with 16 I/O LED indicators and PMOS output for 8 DI, 8DO
JS51053	DIN rail mounted dummy wiring board
M23207	20-pin flat cable 1.5 M
M23209	20-pin flat cable 3.0 M