

DIO3232B

Digital I/O Card

User's Manual (V1.2)

健昇科技股份有限公司

JS AUTOMATION CORP.

新北市汐止區中興路 100 號 6 樓

6F., No.100, Zhongxing Rd.,

Xizhi Dist., New Taipei City, Taiwan

TEL : +886-2-2647-6936

FAX : +886-2-2647-6940

<http://www.automation.com.tw>

<http://www.automation-js.com/>

E-mail : control.cards@automation.com.tw

Correction record

Version	Record
1.0	New
1.0->1.1	1. Add Chapt. 1 Difference between the DIO3232B and DIO3232A
	2. Realignment of specification
1.1->1.2	adopt new point naming convention based on port number
	1. Modify 4.2 DIN rail mounted wiring board
	2. Modify 5.2 ADP3232DIN(N) Din rail mounted wiring board
	3. Add 5.3 ADP3232ADIN(N) Din rail mounted wiring board (V1.3)
	4. Modify 5.4 ADP3232DIN(P) Din rail mounted wiring board
	5. Add 5.5 ADP3232ADIN(P) Din rail mounted wiring board (V1.3)
	6. Modify 5.6 ADP3232DIN(R) Din rail mounted wiring board
	7. Add 5.7 ADP3232ADIN(R) Din rail mounted wiring board (V1.2)
	8. Modify 6.1 JF1 Assignment / Definitions
	9. Modify 8 External wiring diagram
	10. Modify 12 Ordering information

Contents

1.	Difference between the DIO3232B and DIO3232A.....	4
2.	Forward.....	5
3.	Features.....	6
4.	Specifications.....	7
4.1	DIO3232B Main card	7
4.2	DIN rail mounted wiring board	8
5.	Layout and dimensions	9
5.1	DIO3232B Main card	9
5.2	ADP3232DIN(N) Din rail mounted wiring board.....	10
5.3	ADP3232ADIN(N) Din rail mounted wiring board (V1.3)	10
5.4	ADP3232DIN(P) Din rail mounted wiring board	11
5.5	ADP3232ADIN(P) Din rail mounted wiring board (V1.3).....	11
5.6	ADP3232DIN(R) Din rail mounted wiring board	12
5.7	ADP3232ADIN(R) Din rail mounted wiring board (V1.2).....	12
5.8	JS51050 for JM1 25PM Din rail mounted dummy wiring board.....	13
6.	Pin definitions.....	14
6.1	JF1 Assignment / Definitions.....	14
6.2	JM1 Assignment / Definitions	15
7.	I/O interface diagram.....	16
7.1	JF1 ADP3232DIN.....	16
7.2	JM1 JS51050.....	18
8.	External wiring diagram	19
9.	Hardware settings	21
9.1	Card ID setting.....	21
9.2	JP1,JP2 Jumper setting	21
9.3	JP3 Jumper setting	21
10.	Applications.....	22
11.	Application note.....	23
11.1	Tip for using NPN type proximity switch.....	23
11.2	Tip for using PNP type proximity switch	23
12.	Ordering information	24

Notes on hardware installation

Please follow step by step as you are installing the control cards.

1. Be sure your system is power off.
2. Be sure your external power supply for the wiring board is power off.
3. Plug your control card in slot, and make sure the golden fingers are put in right contacts.
4. Fasten the screw to fix the card.
5. Connect the cable between the card and wiring board.
6. Connect the external power supply for the wiring board.
7. Recheck everything is OK before system power on.
8. External power on.

Congratulation! You have it.

For more detail of step by step installation guide, please refer the file “installation.pdf” on the CD come with the product or register as a member of our user’s club at:

<http://automation.com.tw/>

to download the complementary documents.

1. Difference between the DIO3232B and DIO3232A

DIO3232B is the upgrade version of DIO3232A. If you have use the DIO3232A with new driver, you can upgrade seamlessly. The function convention is the same but DIO3232B with more functions such as 2 TTL IO port and more useful IO functions (refer Chapt.3 Features)

2. **Forward**

Thank you for your selection of JAC's product DIO3232B 32 inputs and 32 outputs DIGITAL I/O card for industrial PC. In the field of industrial control, digital I/O is generally controlled under a microprocessor and owing to their specific consideration of industrial environment, it is quite different from the laboratory requirement.

This card is a FPGA based design and our experience in the noise immunity makes this card very stable in the noisy environment and you don't worry about computer down by external noise. We wish the card that will be helpful to your project.

Other DIO series products:

- DIO9201 16 channel input and 16 channel output isolated digital I/O card (ISA bus)
- DIO2232 32 channel input and 32 channel output isolated digital I/O card (ISA bus)
- DIO3206 48 channel TTL digital I/O Card (PCI bus)
- DIO3208B 8 channel input and 8 channel relay output isolated digital I/O card (PCI bus)
- DIO3216B 16 channel input and 16 channel output isolated digital I/O card (PCI bus)
- DIO3217 16 channel input and 16 channel output isolated digital I/O card (PCI bus)
with multifunction timer/counter
- DIO3232A 32 channel input and 32 channel output isolated digital I/O card (PCI bus)
- DIO3248A 48 channel input and 16 channel output isolated digital I/O card (PCI bus)
- DIO3248B Advanced 48 channel input and 16 channel output isolated digital I/O card (PCI bus)
- DIO3264A 64 channel input isolated digital I/O card (PCI bus)
- DIO3264B Advanced 64 channel input isolated digital I/O card (PCI bus)
- DIO3265 64 channel output isolated digital I/O card (PCI bus) with 16 TTL IO
- DIO4264 64 TTL digital I/O PC-104 Module
- DIO6208 8 channel input and 8 channel relay output isolated digital I/O PCI-104 Module
- DIO6216 16 channel input and 16 channel relay output isolated digital I/O PCI-104 Module

Any comment is welcome,

please visit our website

<http://www.automation.com.tw/>

<http://www.automation-js.com/> for the up to date information.

3. Features

- 3.1 PCI plug and play function with card ID for 16 identical cards
- 3.2 32 inputs and 32 outputs are photo-coupler isolated
- 3.3 2 TTL input/output*
- 3.4 Build-in input programmable digital de-bounce circuit*
- 3.5 Accept external interrupt at IN15~ IN0* (IN17 ~IN10 and IN07~IN00)**
- 3.6 8 input with counter function*
- 3.7 32 bit timer on 1us time base*
- 3.8 watch dog timer with default output at OUT7~OUT0* (OUT07~OUT00)**

wiring board

- 3.9 LEDs for corresponding status indication
- 3.10 8 digits per I/O group with Green LED at first digit
- 3.11 Power MOS type output for high speed DC load

*superset functions differ from DIO3232A.

**In DIO3232B and wiring board version A use new convention of point number, it is named under port number, the first digit is port number and the second digit is the point number of the port. In this convention, the point number will be 0~7 (eight points).

4. Specifications

4.1 DIO3232B Main card

Digital input

- 4.1.1 Input channel — 32 ea of ON/OFF switching
- 4.1.2 Rated input voltage — DC 24V
- 4.1.3 Input “ON” state — 2.8V(max) 4.5mA(min)
- 4.1.4 Input “OFF” state — 8V(min) 3mA(max)
- 4.1.5 Switching speed — 10K (limit by photo-coupler speed or by debounce circuit)
- 4.1.6 Debounce — software programmable @ 100,200,1K,2K Hz and no debounce
- 4.1.7 Input counter — 16 bit (IN07 ~ IN00)

Digital output

- 4.1.8 Output channel — 32 ea of ON/OFF switching
- 4.1.9 Output capacity — POWER MOS output:
 - 1A continuous@120Vdc(NMOS max), @ 24Vdc (PMOS max)
 - Relay output: 3A continuous@250Vac(max)

TTL IO

- 4.1.10 Port — 2
- 4.1.11 Direction — software programmable on port base

Timer

- 4.1.12 Length — 32 bit @1us
- 4.1.13 Interrupt — time up interrupt

General

- 4.1.14 Card ID — 4 bits
- 4.1.15 Insulation resistance — 100M Ohm (min) at 1000Vdc
- 4.1.16 Isolation voltage — 2500Vac 1Min
- 4.1.17 PCI bus data width — 32 bits
- 4.1.18 I/O connector — 68 pin female SCSI II connector
- 4.1.19 Wiring board — 1 with round cable hook to main card
- 4.1.20 External supply — DC 24±4V
- 4.1.21 Operation temperature — 0 to 70° C
- 4.1.22 Storage temperature — -20° to 80° C
- 4.1.23 Operation humidity — RH5~95%, non-condensed
- 4.1.24 Dimension — 159(W) * 106(H) mm, 6.3(W) * 4.2(H)in

4.2 DIN rail mounted wiring board

ADP3232DIN/ADP3232ADIN Din rail mounted wiring board

- 4.2.1 External supply — DC 24V±4V
- 4.2.2 Input status indicator — 32 LED, 8 digit per group with Green LED at first digit
- 4.2.3 Output status indicator — 32 LED, 8 digit per group with Green LED at first digit
- 4.2.4 Power indicator — Red LED
- 4.2.5 Terminal — every 4 has one common terminal.
(Different “common” for different positive power terminal)
- 4.2.6 Output capacity — NMOS : 1A continuous@120Vdc
PMOS: 1A continuous@24Vdc
Relay : 3A continuous@250Vac(max)
- 4.2.7 Operation temperature — 0 to 70° C
- 4.2.8 Operation humidity — RH5~95%, non-condensed
- 4.2.9 Dimension — ADP3232DIN(N)/ADP3232ADIN(N) : 121(W) * 159(L) * 47(H)mm
4.8(W)*6.3(L)*1.9(H)in
ADP3232DIN(P)/ADP3232ADIN(P) : 121(W) * 159(L) * 45(H)mm
4.8(W)*6.3(L)*1.8(H)in
ADP3232DIN(R)/ADP3232ADIN(R) : 121(W) * 204(L) * 45(H)mm
4.8(W)*8.1(L)*1.8(H)in

JS51050 25PM Din rail mounted dummy wiring board for TTL I/O

- 4.2.10 Connection cable — D-type 25P cable to connect main and wiring board
- 4.2.11 Dimension — 86(W)*79(L)*52(H)mm , 3.4(W)*3.2(L)*2.1(H)in

5. Layout and dimensions

5.1 DIO3232B Main card

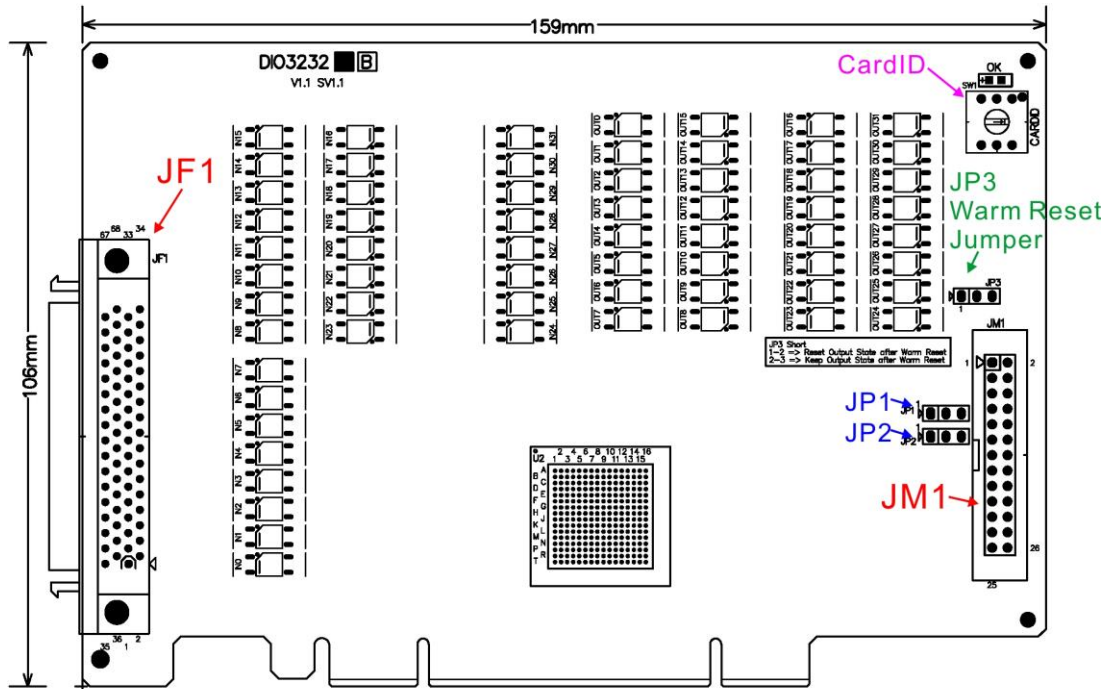

*dimension in bare board

5.2 ADP3232DIN(N) Din rail mounted wiring board

Note: The I/O pints are enumerated from 0 to 31 without port designation.

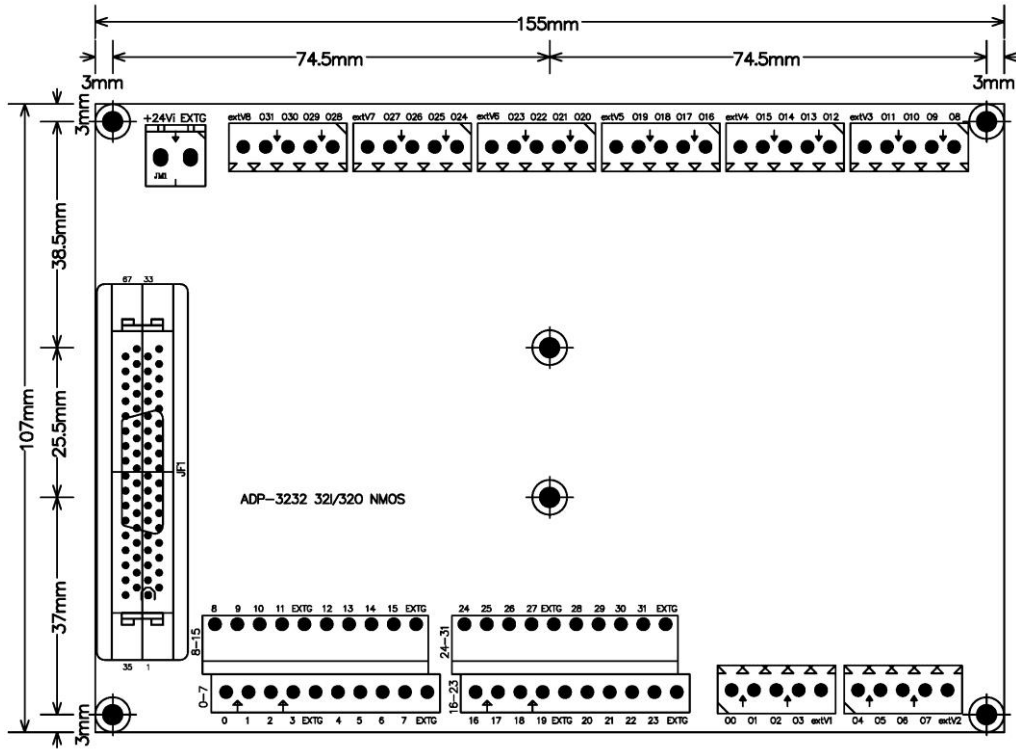

*dimension in bare board

5.3 ADP3232ADIN(N) Din rail mounted wiring board (V1.3)

Note: The I/O pints are enumerated from 00 to 37 with first digit as port designation.

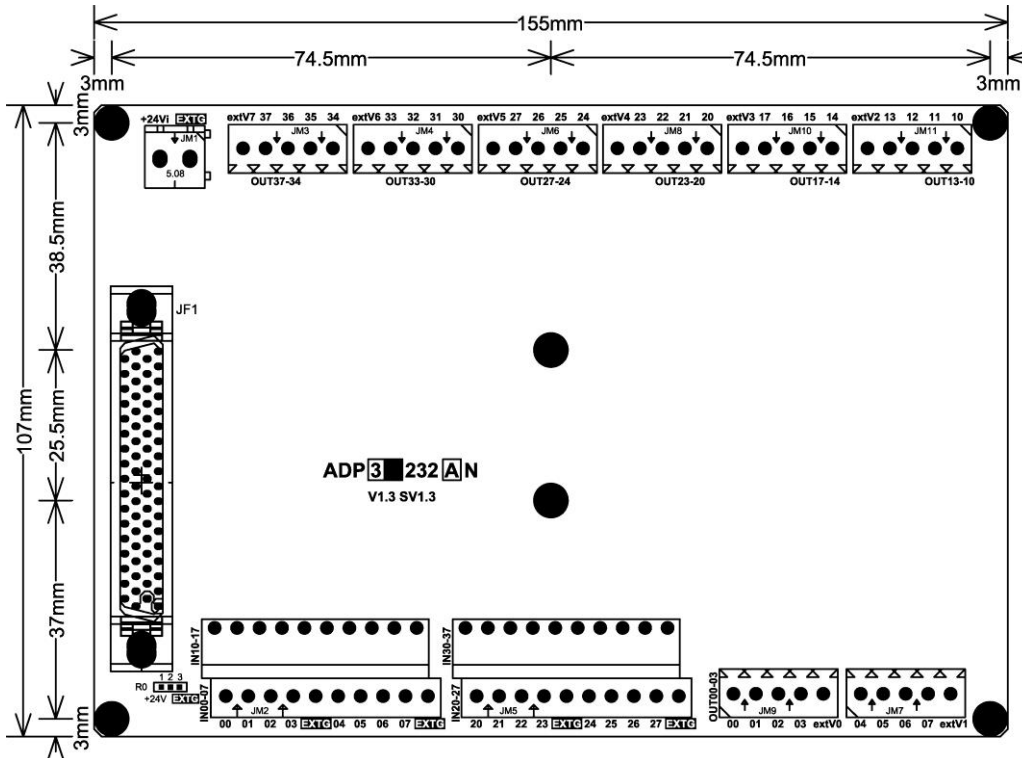

*dimension in bare board

5.4 ADP3232DIN(P) Din rail mounted wiring board

Note: The I/O pints are enumerated from 0 to 31 without port designation.

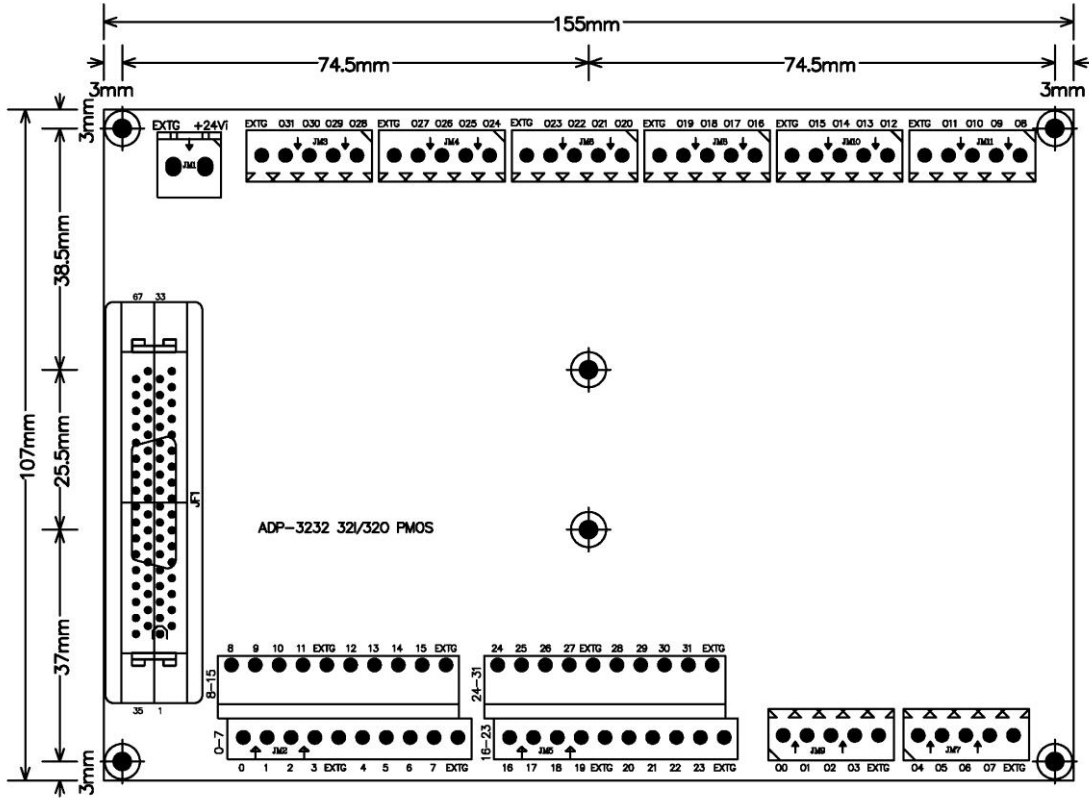

*dimension in bare board

5.5 ADP3232ADIN(P) Din rail mounted wiring board (V1.3)

Note: The I/O pints are enumerated from 00 to 37 with first digit as port designation.

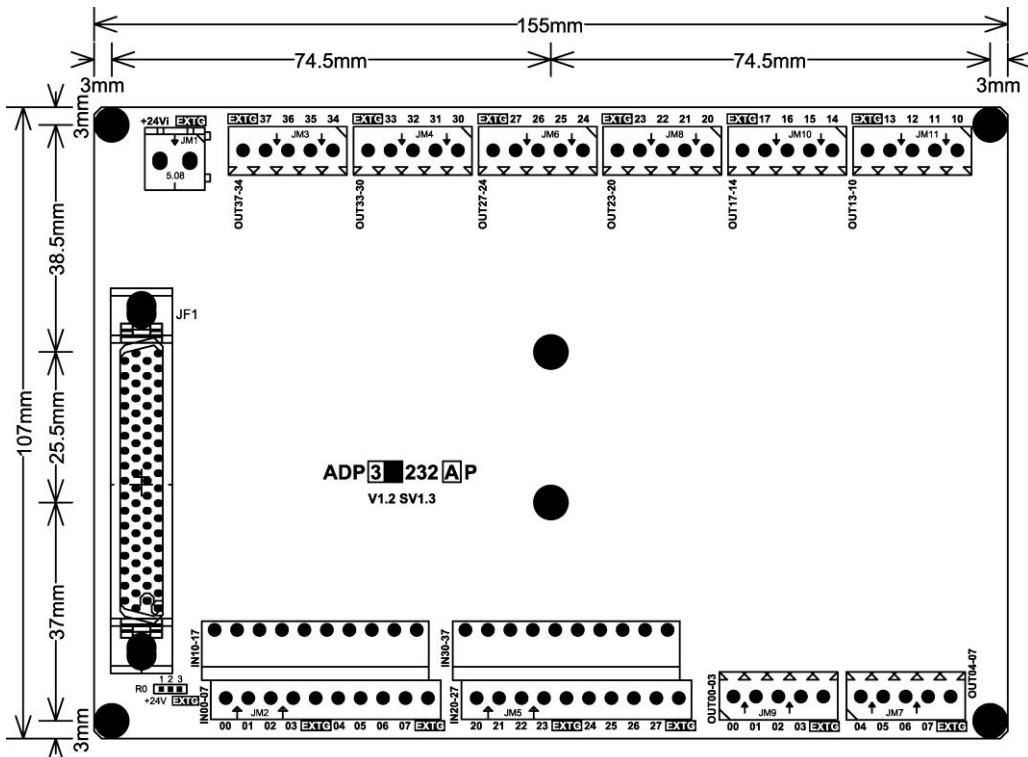

*dimension in bare board

5.6 ADP3232DIN(R) Din rail mounted wiring board

Note: The I/O pints are enumerated from 0 to 31 without port designation.

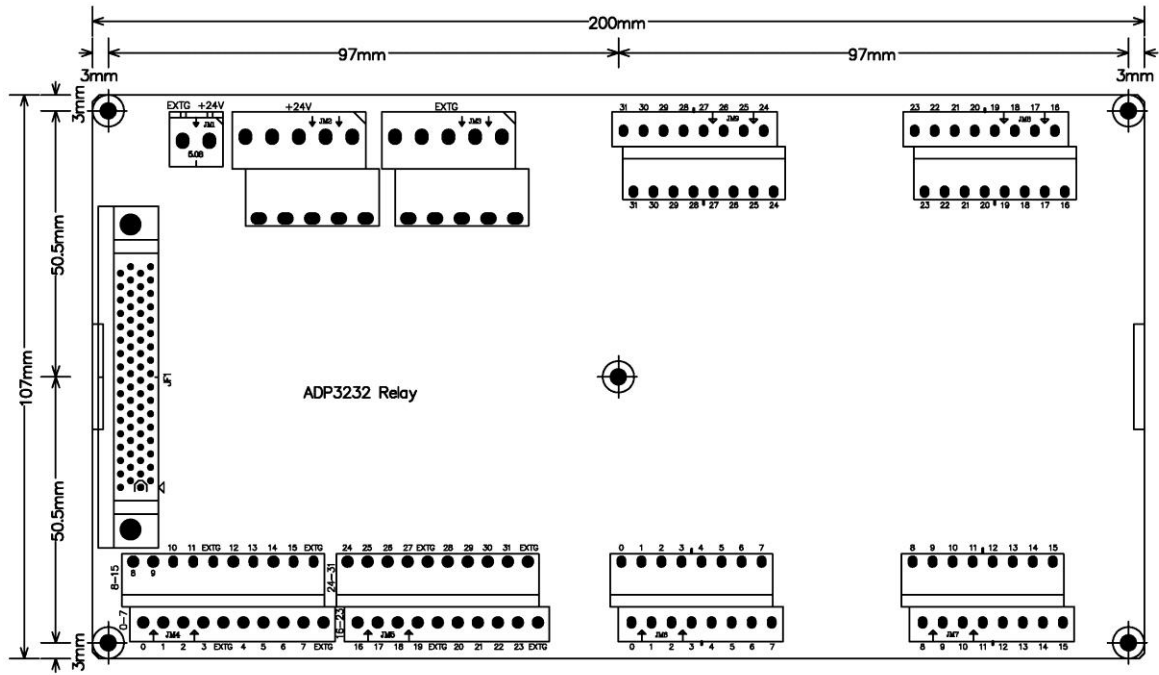

*dimension in bare board

5.7 ADP3232ADIN(R) Din rail mounted wiring board (V1.2)

Note: The I/O pints are enumerated from 00 to 37 with first digit as port designation.

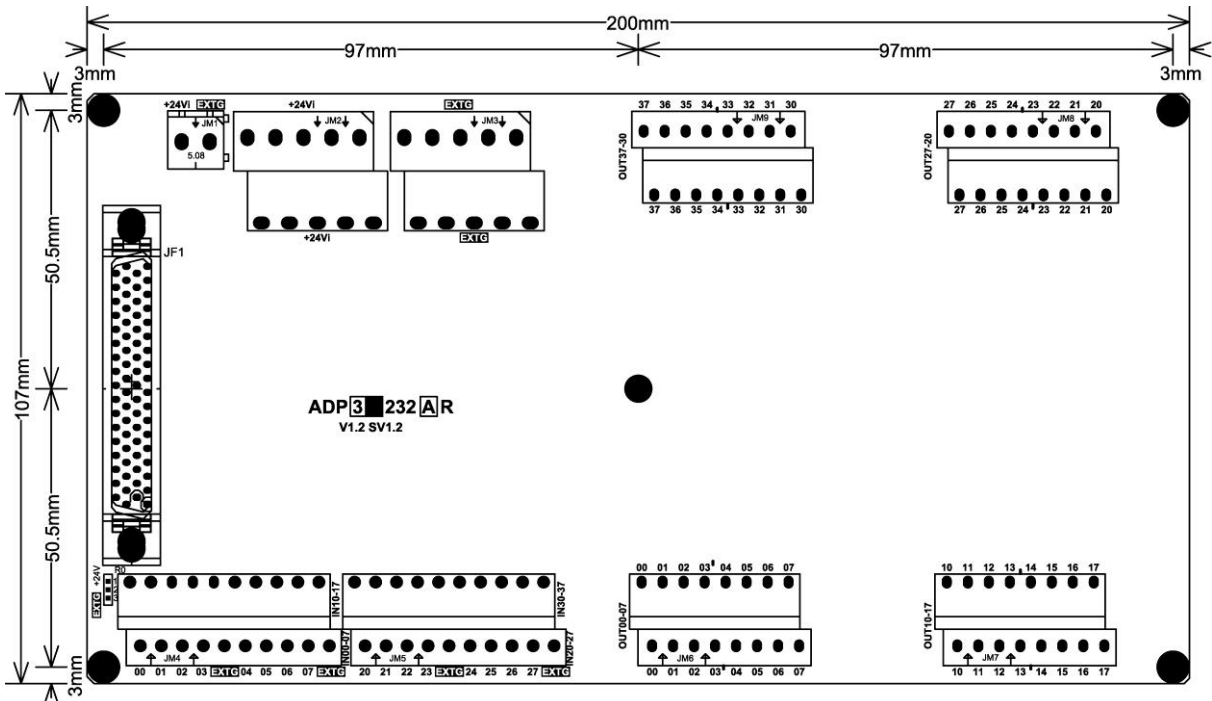

*dimension in bare board

5.8 JS51050 for JM1 25PM Din rail mounted dummy wiring board

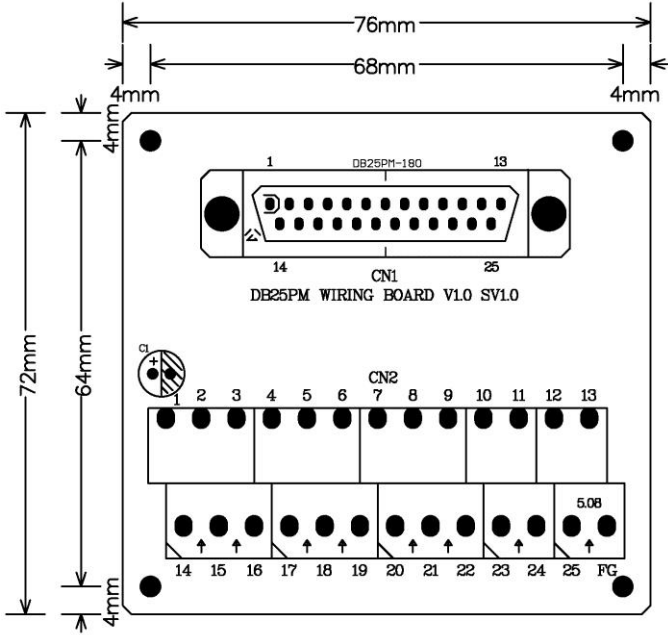

*dimension in bare board

6. Pin definitions

6.1 JF1 Assignment / Definitions

PIN	Descriptions		PIN	Descriptions
68	+24V[External DC24V power]		34	+24V[External DC24V power]
67	+24V[External DC24V power]		33	+24V[External DC24V power]
66	OUT37[External Output 37]		32	OUT36[External Output 36]
65	OUT35[External Output 35]		31	OUT34[External Output 34]
64	OUT33[External Output 33]		30	OUT32[External Output 32]
63	OUT31[External Output 31]		29	OUT30[External Output 30]
62	OUT27[External Output 27]		28	OUT26[External Output 26]
61	OUT25[External Output 25]		27	OUT24[External Output 24]
60	OUT23[External Output 23]		26	OUT22[External Output 22]
59	OUT21[External Output 21]		25	OUT20[External Output 20]
58	OUT17[External Output 17]		24	OUT16[External Output 16]
57	OUT15[External Output 15]		23	OUT14[External Output 14]
56	OUT13[External Output 13]		22	OUT12[External Output 12]
55	OUT11[External Output 11]		21	OUT10[External Output 10]
54	OUT07[External Output 07]		20	OUT06[External Output 06]
53	OUT05[External Output 05]		19	OUT04[External Output 04]
52	OUT03[External Output 03]		18	OUT02[External Output 02]
51	OUT01[External Output 01]		17	OUT00[External Output 00]
50	IN37[External Input 37]		16	IN36[External Input 36]
49	IN35[External Input 35]		15	IN34[External Input 34]
48	IN33[External Input 33]		14	IN32[External Input 32]
47	IN31[External Input 31]		13	IN30[External Input 30]
46	IN27[External Input 27]		12	IN26[External Input 26]
45	IN25[External Input 25]		11	IN24[External Input 24]
44	IN23[External Input 23]		10	IN22[External Input 22]
43	IN21[External Input 21]		9	IN20[External Input 20]
42	IN17[External Input 17]		8	IN16[External Input 16]
41	IN15[External Input 15]		7	IN14[External Input 14]
40	IN13[External Input 13]		6	IN12[External Input 12]
39	IN11[External Input 11]		5	IN10[External Input 10]
38	IN07[External Input 07]		4	IN06[External Input 06]
37	IN05[External Input 05]		3	IN04[External Input 04]
36	IN03[External Input 03]		2	IN02[External Input 02]
35	IN01[External Input 01]		1	IN00[External Input 00]

6.2 Wiring board I/O point designation cross reference

port	wiring board (ADP3232DIN)	wiring board (ADP3232ADIN)
0	0 ~ 7	00 ~ 07
1	8 ~ 15	10 ~ 17
2	16 ~ 23	20 ~ 27
3	23~ 31	30 ~ 37

6.3 JM1 Assignment / Definitions

PIN	Description				PIN	Description
1	IO00: TTL port0 IO0	IO00	1	14	IO10	IO10: TTL port1 IO0
2	IO01: TTL port0 IO1	IO01	2	15	IO11	IO11: TTL port1 IO1
3	IO02: TTL port0 IO2	IO02	3	16	IO12	IO12: TTL port1 IO2
4	IO03: TTL port0 IO3	IO03	4	17	IO13	IO13: TTL port1 IO3
5	IO04: TTL port0 IO4	IO04	5	18	IO14	IO14: TTL port1 IO4
6	IO05: TTL port0 IO5	IO05	6	19	IO15	IO15: TTL port1 IO5
7	IO06: TTL port0 IO6	IO06	7	20	IO16	IO16: TTL port1 IO6
8	IO07: TTL port0 IO7	IO07	8	21	IO17	IO17: TTL port1 IO7
9	GND	GND	9	22	GND	GND
10	GND	GND	10	23	GND	GND
11	GND	GND	11	24	GND	GND
12	+5Vout_PC: 5V out from PC	+5Vout_PC	12	25	+5Vout_PC	+5Vout_PC: 5V out from PC
13	+5Vout_PC: 5V out from PC	+5Vout_PC	13			

7. I/O interface diagram

7.1 JF1 ADP3232DIN

7.1.1 Input diagram

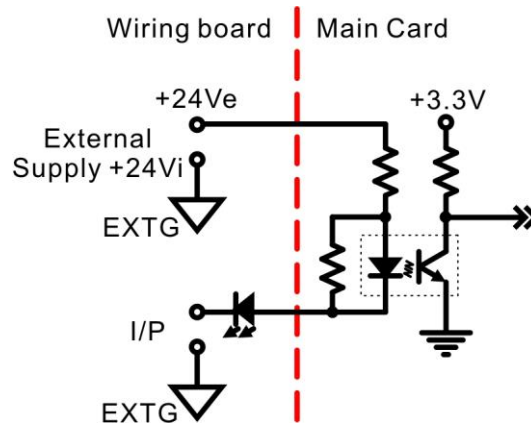

7.1.2 Output diagram

Type 1 output : NMOS

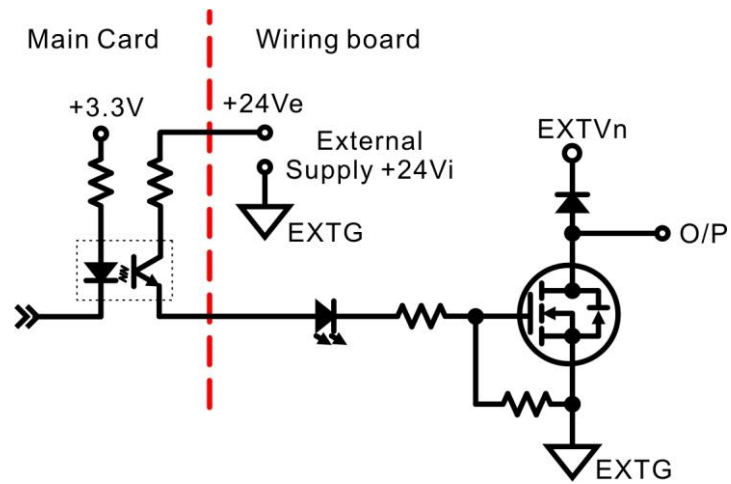

Type 2 output : PMOS

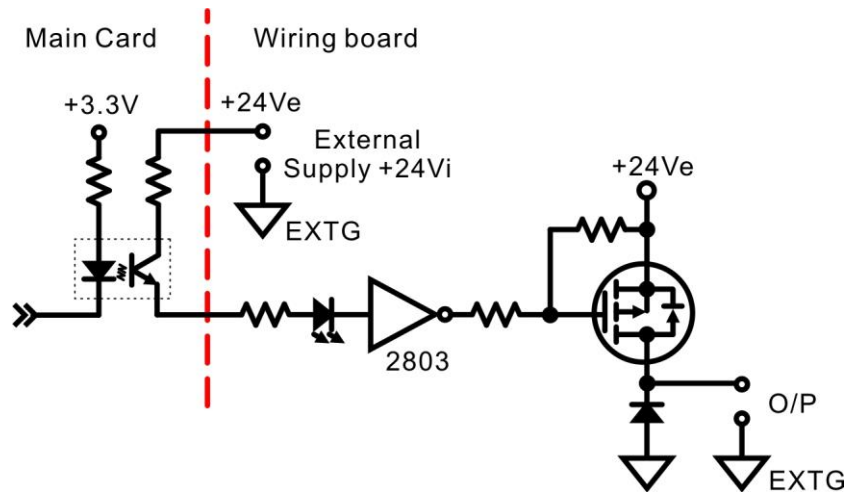

Type 3 output : RELAY

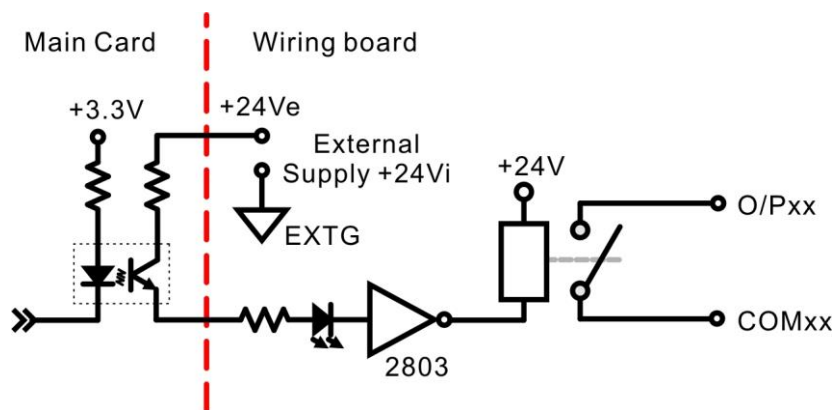

7.2 JM1 JS51050

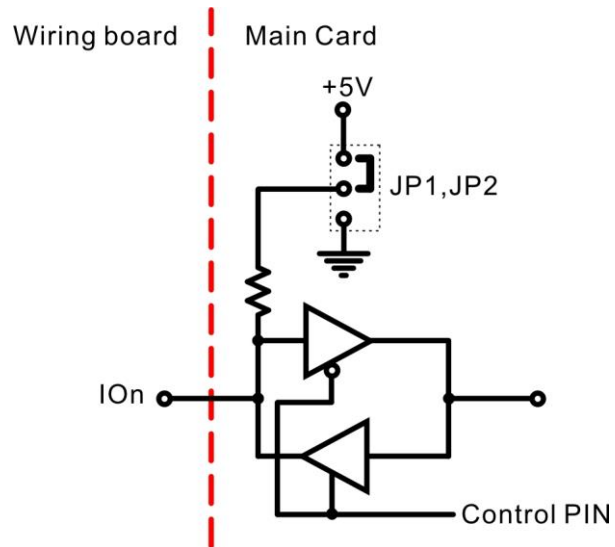

For byte-programmable TTL I/O IO00 ~ IO07, IO10 ~ IO17 to configured as pull high or pull low. JP1,JP2 are used for output state of power on. (refer 9.2 JP1,JP2 Jumper setting)

8. External wiring diagram

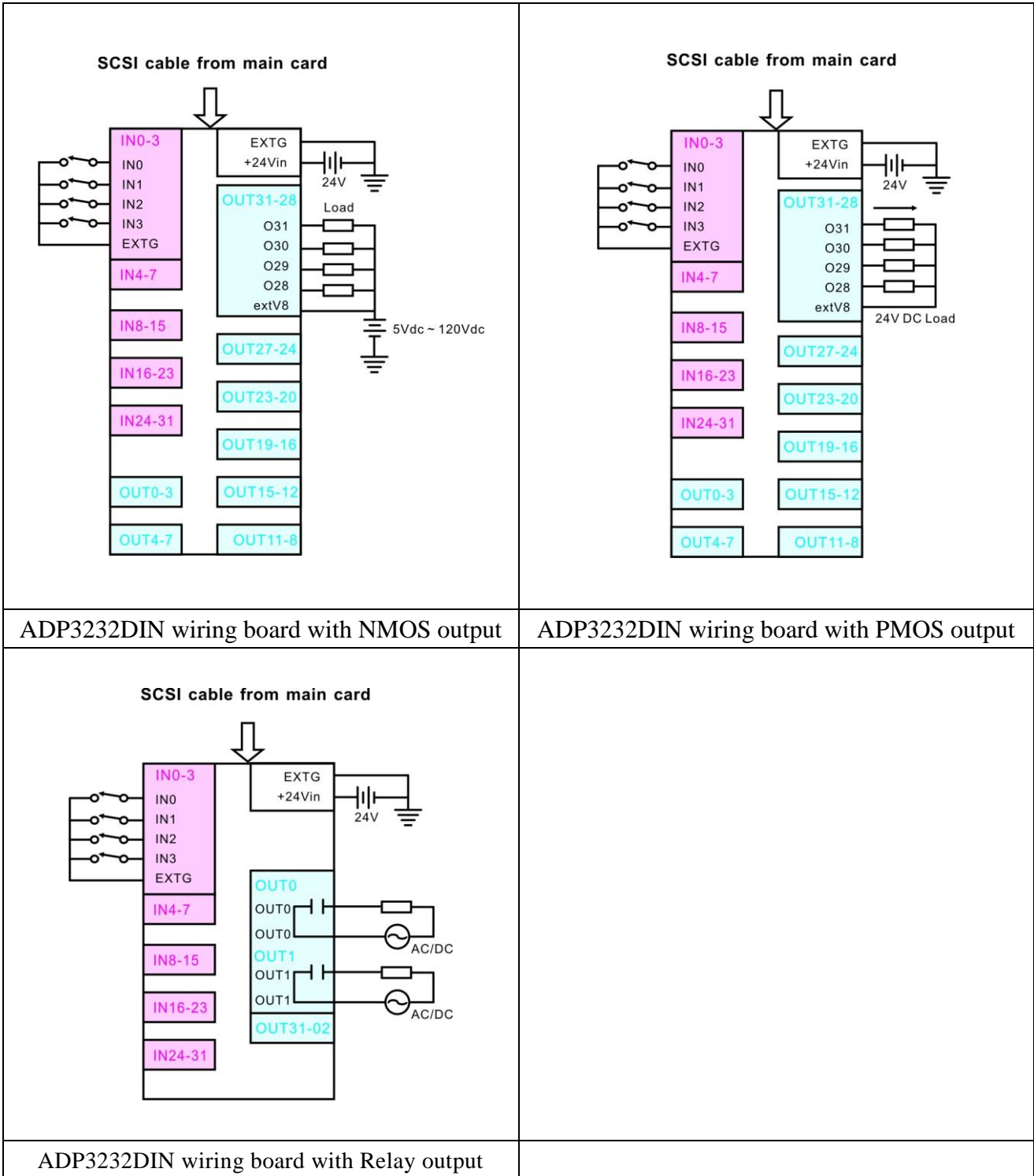

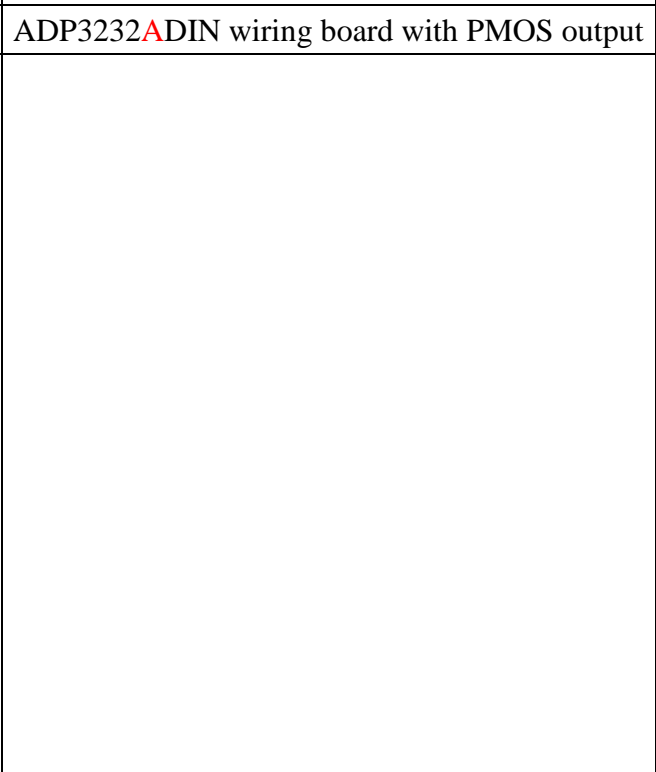
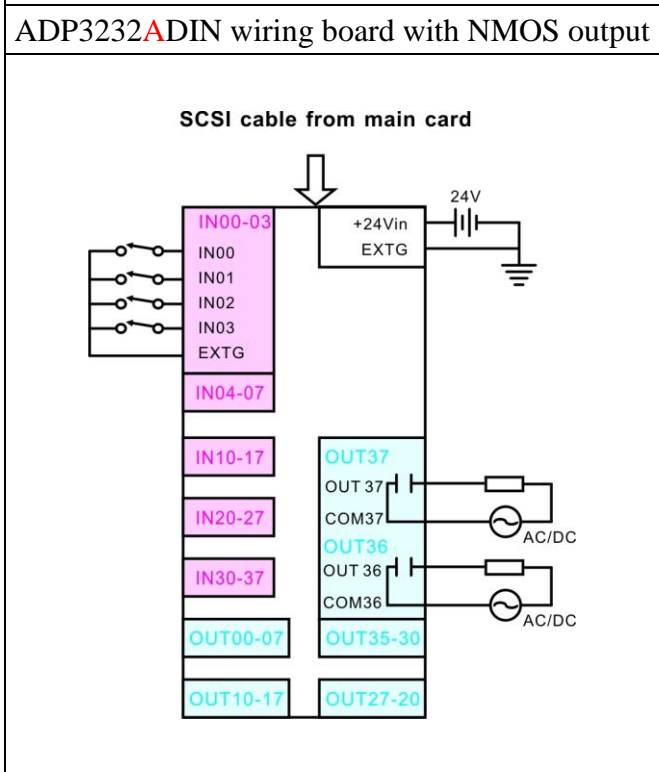
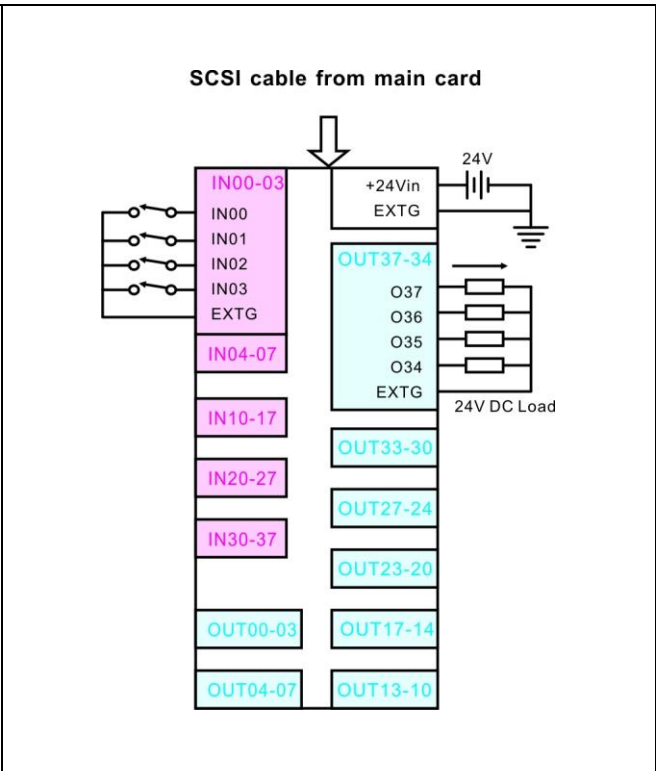
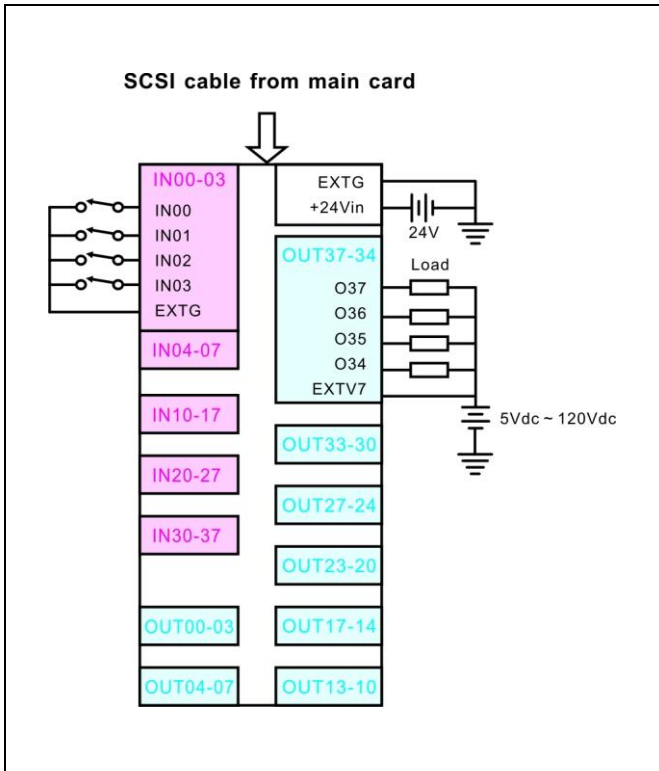

Note: The ADP3232ADIN wiring board I/O points are enumerated from 00 to 37 with first digit as port designation.

9. Hardware settings

9.1 Card ID setting

Since PCI cards have plug and play function, the card ID is required for programmer to identify which card he/she will control without knowing the physical address assigned by the Windows. A rotary switch for distinguishing the 16 identical card.

The following example sets the card ID at 0.

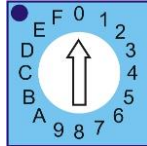

9.2 JP1,JP2 Jumper setting

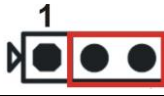
	
1-2 short Pull High	2-3 short Pull Low

Jumper JP1 and JP2 is used for the TTL output default state, if you disable the TTL port or at computer start-up period, the default state will be output. Select the one to match with the succeeding circuit.

9.3 JP3 Jumper setting

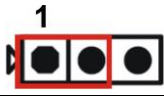
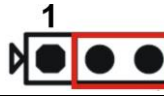
	
Reset output after warm reset	Keep output after warm reset

10. Applications

- Accept : -- P.B./M.S./EMG./Contact- Start/Stop/Limit switch/sensor
 - Interlock/selective Sw.- Proximity switch
 - Aux. contact of transducer/detector
- As I/O of S/W PLC Controller
 - Power MOS type output: drive high speed DC load

11. Application note

11.1 Tip for using NPN type proximity switch

The NPN type proximity sensor can directly connect to input of wring board.

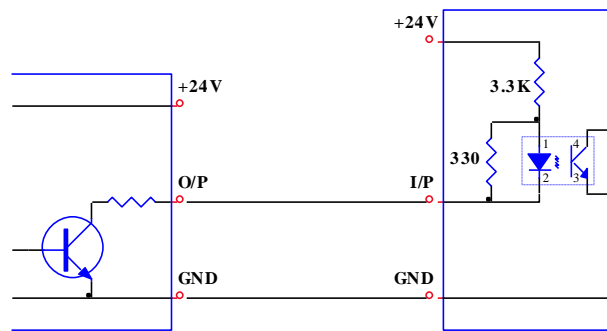
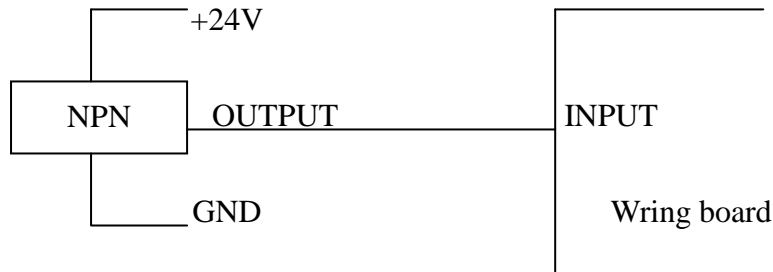

11.2 Tip for using PNP type proximity switch

The PNP type proximity sensor need extra pull down resistor connect to input of wring board.

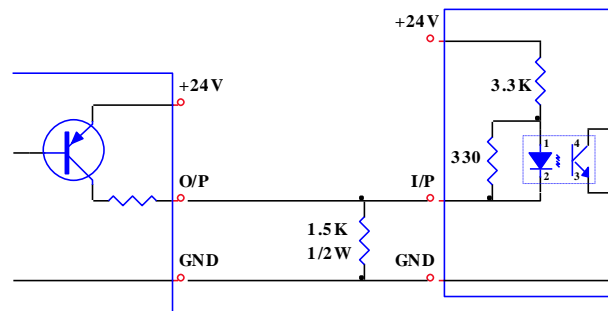
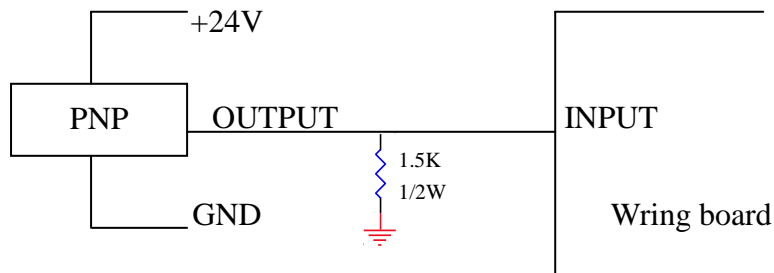

12. Ordering information

<u>PRODUCT</u>	<u>DESCRIPTIONS</u>
DIO3232B	advanced 64-channel Digital I/O Card for 32 DI and 32 DO Photo-coupler isolated
ADP3232DIN(N)	DIN rail mounted wiring board for 32 input and 32 power NMOS output (To be phase out, please select new model ADP3232ADIN(N))
ADP3232DIN(P)	DIN rail mounted wiring board for 32 input and 32 power PMOS output (To be phase out, please select new model ADP3232ADIN(P))
ADP3232DIN(R)	DIN rail mounted wiring board for 32 input and 32 power RELAY output (To be phase out, please select new model ADP3232ADIN(R))
ADP3232ADIN(N)	DIN rail mounted wiring board for 32 input and 32 power NMOS output
ADP3232ADIN(P)	DIN rail mounted wiring board for 32 input and 32 power PMOS output
ADP3232ADIN(R)	DIN rail mounted wiring board for 32 input and 32 power RELAY output
JS51050	DIN rail mounted dummy wiring board (D type 25P male to terminals) for JM1 TTL I/O
M266868150	68 pin SCSI II cable 1.5M
M266868300	68 pin SCSI II cable 3.0M
M270325X4	D type 25p male-female cable 1.5M
M270325X4S	D type 25p male-female cable 1.5M, shielding
M270325X0	D type 25p male-female cable 3.0M
M270325X0S	D type 25p male-female cable 3.0M, shielding
SM23404	Extension kit for JM1 (bracket and flat cable for 25P female D type connector)