

LSI3101/3101A

**Quadrature Encoder/Linear Scale
Counter Card**

User's Manual (V1.4)

健昇科技股份有限公司

JS AUTOMATION CORP.

新北市汐止區中興路 100 號 6 樓

6F., No.100, Zhongxing Rd.,

Xizhi Dist., New Taipei City, Taiwan

TEL : +886-2-2647-6936

FAX : +886-2-2647-6940

<http://www.automation.com.tw>

<http://www.automation-js.com/>

E-mail : control.cards@automation.com.tw

Correction record

Version	Record
1.0	firmware version 1.0 up
1.1	add LSI3101A
1.2	add LSI3101 V1.2 SV1.1 diagram
	add JP1 description
1.3	Modify 2. Feature-Delete Software key function
1.4	add ADP3101 V1.2 SV1.2 diagram

Contents

1.	Forward.....	4
2.	Features.....	5
2.1	Main card	5
2.2	Din rail mounted wiring board.....	6
3.	Specifications.....	7
3.1	LSI3101/3101A Main card.....	7
3.2	Din rail mounted wiring board.....	9
4.	Layout and dimensions	10
4.1	LSI3101/3101A Main card.....	10
4.2	ADP3101DIN Din rail mounted wiring board.....	11
4.3	ADP9201DIN Din rail mounted wiring board.....	12
4.4	JS51053 for ADP9201_JM1 20PM Din rail mounted dummy wiring board	12
5.	Pin definitions for main card connectors	13
5.1	JF1 pin definitions.....	13
5.2	ADP9201_JM1 pin definitions	13
6.	I/O Interface diagram.....	14
6.1	JF1 ADP3101DIN.....	14
6.2	ADP9201_JM1 ADP9201DIN.....	15
7.	Using wiring board	17
7.1	ADP3101DIN wiring board	17
7.2	ADP9201DIN wiring board	18
8.	Main card hardware settings	19
8.1	Card ID setting	19
8.2	JP1 warm reset jumper	19
9.	Applications.....	20
10.	Ordering information	21

Notes on hardware installation

Please follow step by step as you are installing the control cards.

1. Be sure your system is power off.
2. Be sure your external power supply for the wiring board is power off.
3. Plug your control card in slot, and make sure the golden fingers are put in right contacts.
4. Fasten the screw to fix the card.
5. Connect the cable between the card and wiring board.
6. Connect the external power supply for the wiring board.
7. Recheck everything is OK before system power on.
8. External power on.

Congratulation! You have it

For more detail of step by step installation guide, please refer the file “installation.pdf” on the CD come with the product or register as a member of our user’s club at:

<http://automation.com.tw/>

to download the complementary documents.

1. **Forward**

Thank you for your selection of PCI bus LSI3101/3101A quadrature encoder/linear scale interface card.

In the field of automation, encoder and linear scale as feedback or measuring element is common used in the microprocessor control system. But for the versatile application in PC based control, only a few selections you can make.

With the state of the art technology of FPGA chip, photo/magnetic coupler isolation and experienced functions such as external triggered clear counter, auto increment compare equal or FIFO pre-programmed compare equal output to trigger external devices, low cost and high performance makes this card a better choice to use in the servo control feedback and other applications which are concerning quadrature encoder or linear scale.

Other encoder/linear scale interface card:

- LSI3104 4 axes quadrature encoder/linear scale counter card (PCI bus)
- LSI3123L low cost 3 axes quadrature encoder/linear scale counter card
(no touch probe trigger latch function) (PCI bus)
- LSI3123 3 axes quadrature encoder/linear scale counter card (PCI bus)
- LSI3123A 3 axes quadrature encoder/linear scale counter card
with fast coordinate rebuild function (PCI bus)
- LSI3134 4 axes quadrature encoder/linear scale counter card
with 1 axis FIFO compare mode (PCI bus)
- LSI3144 4 axes quadrature encoder/linear scale counter card
with 2 axes FIFO compare mode (PCI bus)
- LSI5123 3 axes quadrature encoder counter interface (USB)
- LSI5123L 3 axes quadrature encoder counter interface (no external trigger latch mode) (USB)
- LSI5123A 3 axes quadrature encoder counter interface (High noise immunity , Accurite linear
scale absolute coordinate mode) (USB)

Any comment is welcome,

please visit our website

<http://www.automation.com.tw/>

<http://www.automation-js.com/> for the up to date information.

2. Features

2.1 Main card

- 2.1.1 PCI plug and play function with card ID for 16 identical cards
- 2.1.2 High noise immunity with magnetic/photo-coupler isolation
- 2.1.3 Supports DIN rail mounted wiring board
- 2.1.4 32bit timer based on 1us time base

DIO block

- 2.1.5 8 photo isolated digital input
- 2.1.6 8 photo isolated digital output
- 2.1.7 Software debounce for digital input
- 2.1.8 Software programmable I/O polarity
- 2.1.9 Interrupt from IN00~IN07

Quadrature counter block

- 2.1.10 32-bit counter
- 2.1.11 16 MHz max. Quadrature input rate (LSI3101A)
8 MHz max. Quadrature input rate (LSI3101)
- 2.1.12 Quadrature, pulse/direction and up/down counting
- 2.1.13 Programmable multiple rate at X1, X2, X4
- 2.1.14 Software debounce for input signals
- 2.1.15 Multiple counter reset (homing) modes
- 2.1.16 Differential or single-end input signal
- 2.1.17 Single or auto increment compare mode
- 2.1.18 FIFO compare mode
- 2.1.19 Output gated control
- 2.1.20 Programmable duration for Compare output
- 2.1.21 Interrupt on compare equal, FIFO near end

2.2 Din rail mounted wiring board

2.2.1 LED display for digital I/O

2.2.2 Application specific connectors

2.2.3 Step down s.p.s. for external 5V

3. **Specifications**

3.1 LSI3101/3101A Main card

Counter block

- 3.1.1 Number of axes: 1
- 3.1.2 Input : 5 magnetic isolation (A,B,Z,CLEAR,HOME input), TTL level
- 3.1.3 Output : 1 magnetic isolation (compare out), TTL level
- 3.1.4 Maximum quadrature input frequency : 8MHz x 4 (LSI3101)
16MHz x 4(LSI3101A)
- 3.1.5 Encoder Type: Single-end or differential (with ADP3101 DIN wiring board)
- 3.1.6 Input software debounce:
for LSI3101: 512k, 1M, 2M, 4M, 8M (programmable)
for LSI3101A:512k, 1M, 2M, 4M, 8M,10M,16M (programmable)
- 3.1.7 Input multiple rate: X1, X2, X4 programmable (quadrature signal only)
- 3.1.8 Counter length : 32 Bits
- 3.1.9 Counter Mode : (QUADRATURE) , (CLOCK/DIRECTION) ,
(UP CLOCK/ DOWN CLOCK)
- 3.1.10 Sample clock frequency: 33MHz
- 3.1.11 PCI data width : 32 Bits
- 3.1.12 FIFO depth : 1023
- 3.1.13 Compare out one shot duration : 1 ~ 65535 us

Digital block

- 3.1.14 Input : 8 photo-isolated ,
- 3.1.15 ON state : 2.8Vdc(max) 4.5mA(min)
- 3.1.16 OFF state : 8Vdc(min) 3mA(max)
- 3.1.17 Switching speed : 10KHz max. (limit by photo coupler speed and debounce filter)
- 3.1.18 Software debounce: 100Hz, 200Hz, 1KHZ, No debounce (programmable)
- 3.1.19 Interrupt at IN00 ~ IN07

- 3.1.20 Output : 8 photo-isolated,
- 3.1.21 Output range : Open collector 0 ~ 45 Vdc (on card)
- 3.1.22 Output rating : (With ADP3101 DIN wiring board)
 - 3A @250Vac, 30Vdc (Relay)
 - 1A @ 24Vdc (PMOS)
 - 2A @ 240Vac (SSR)
- 3.1.23 Sink current : 500mA(peak) per channel (on card)
- 3.1.24 Switching speed : 20KHz(max)(MOS out only)

Timer block

- 3.1.25 Timer time base: 1us
- 3.1.26 Timer/counter length:32 bit

General

- 3.1.27 Card ID : 4 bits, 16 position
- 3.1.28 Insulation resistance : 1000Mohm (min) at 1000Vdc
- 3.1.29 Isolation voltage : 2500Vac 1 min
- 3.1.30 Connector : one 20 pin SCSI-II female connector
one 20 pin flat cable connector
- 3.1.31 Operation temperature : 0 to +70 degree C
- 3.1.32 Storage temperature : -20 to +80 degree C
- 3.1.33 Operation humidity : 5-95% RH, non-condensing
- 3.1.34 Dimension : 130(W) * 102(H)mm , 5.2(W) * 4.1(H)in

3.2 Din rail mounted wiring board

ADP3101DIN DIN rail mounted wiring board

- 3.2.1 External Supply : DC 24V \pm 4V
- 3.2.2 Single end/ differential signal : jumper select
- 3.2.3 Connector: SCSI-II 20P cable to connect main and wiring board
- 3.2.4 On board build-in s.p.s. : DC+5V 500mA (max)
- 3.2.5 Dimension : 86(W) * 103(L) *45(H)mm;
3.4(W)*4.1(L)*1.8(H)in

ADP9201DIN DIN rail mounted wiring board

- 3.2.6 External Supply : DC 24V \pm 4V
- 3.2.7 Input : 8 with LED indicator
- 3.2.8 Output : ADP9201DIN(R) : 8 relays (3A @250Vac, 3A @30Vdc) with LED indicator
ADP9201DIN(S) : 8 SSR (2A @240Vac) with LED indicator
ADP9201DIN(P) : 8 PMOS (Source 1A @24Vdc) with LED indicator
- 3.2.9 Connector: One 20-pin male flat-cable connector
- 3.2.10 Operation Temperature: 0 to +70 degree C
- 3.2.11 Operation Humidity: RH5~95%, non-condensing
- 3.2.12 Dimension: ADP9201DIN(R) / (P) : 86(W) * 103(L) *45(H)mm;
3.4(W)*4.1(L)*1.8(H)in
ADP9201DIN(S) : 86(W) * 103(L) *50(H)mm
3.4(W)*4.1(L)*2.0(H)in

JS51053 20PM Din rail mounted dummy wiring board

- 3.2.13 Dimension: 86(W)*79(L)*52(H)mm, 3.4(W)*3.2(L)*2.1(H)in

4. Layout and dimensions

4.1 LSI3101/3101A Main card

LSI3101 V1.0 SV1.0

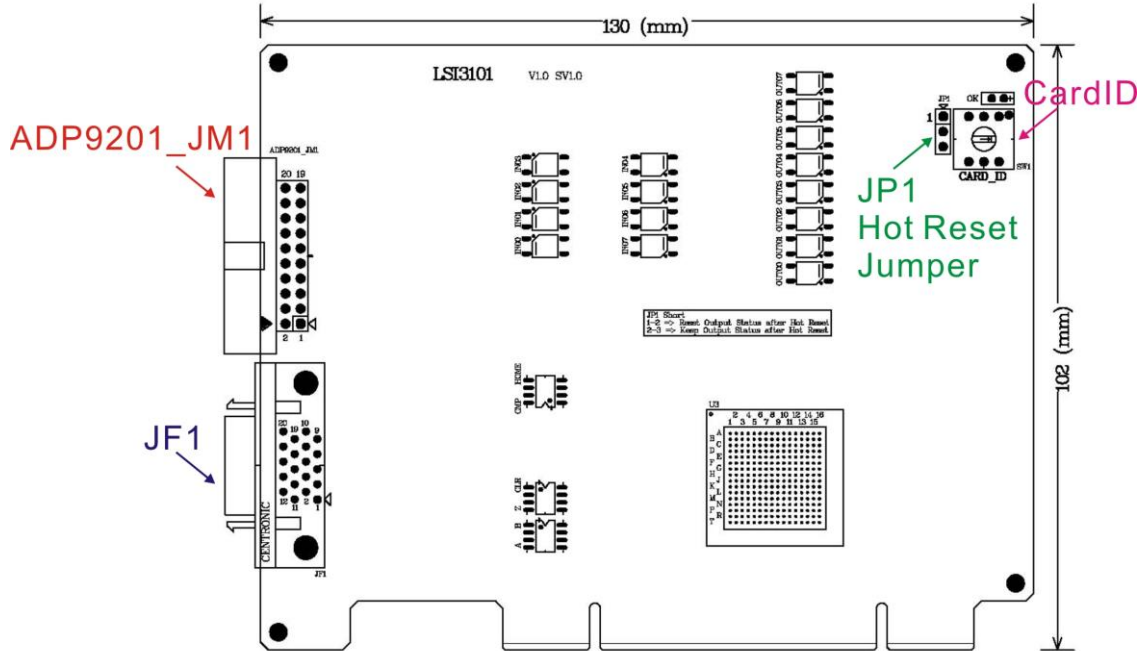

LSI3101 V1.2 SV1.1

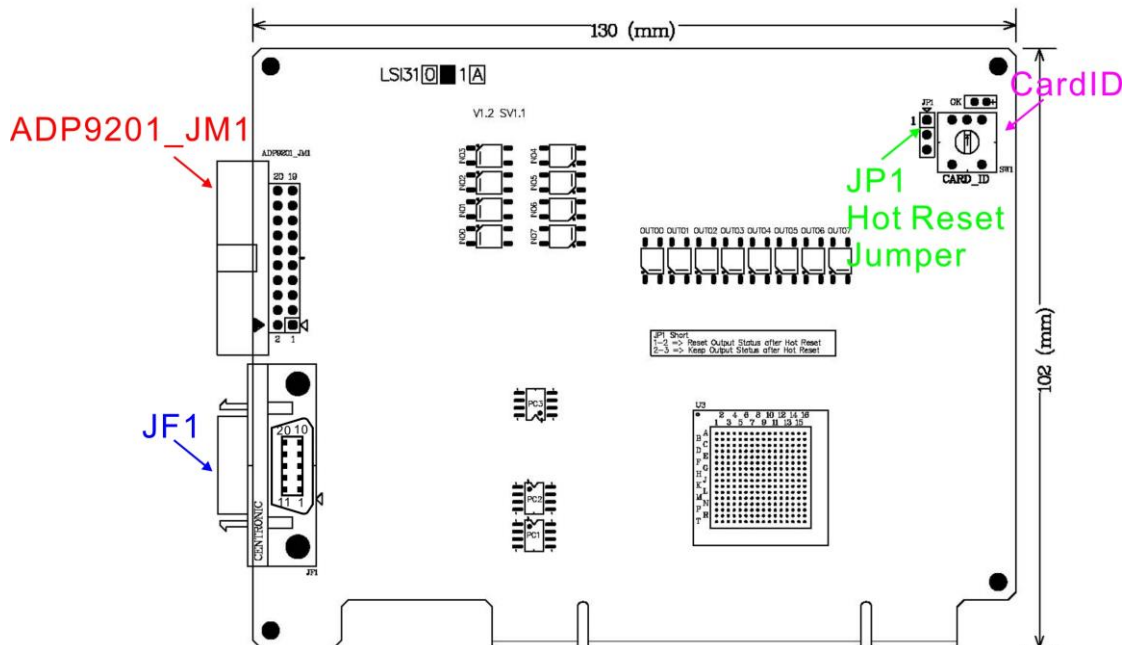

Note: Both the two versions are software and hardware compatible

4.2 ADP3101DIN Din rail mounted wiring board

ADP3101 V1.1 SV1.1

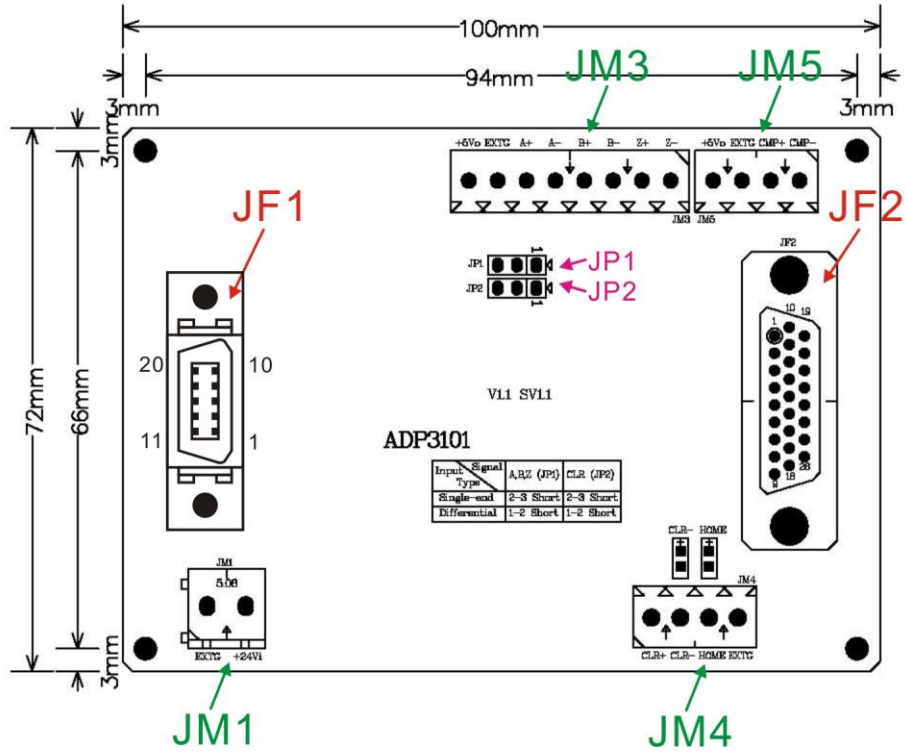

ADP3101 V1.2 SV1.2

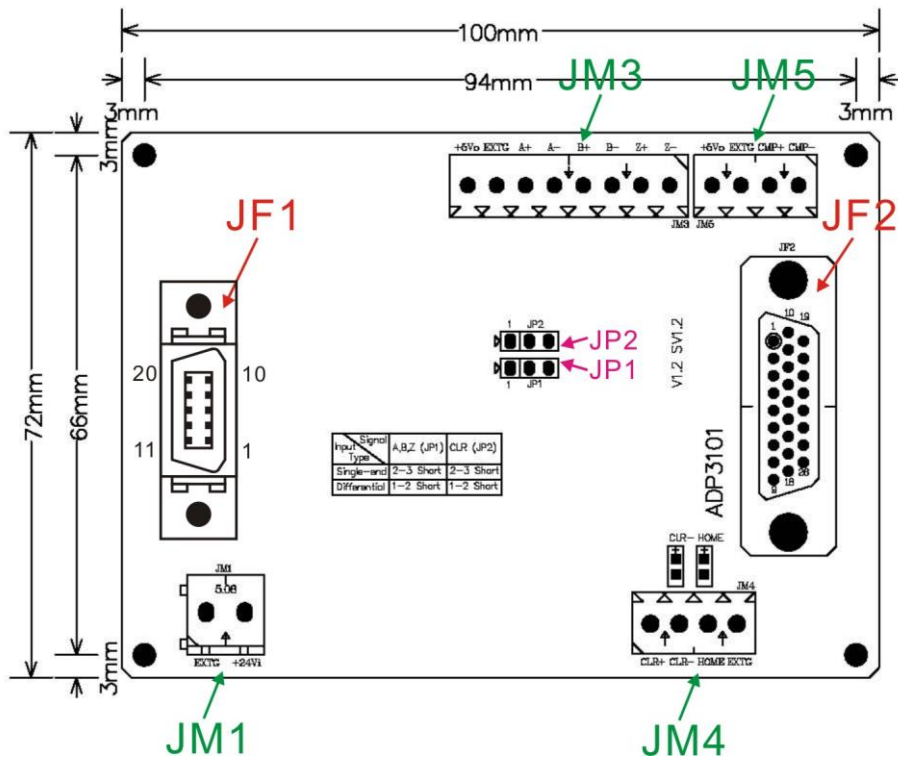

4.3 ADP9201DIN Din rail mounted wiring board

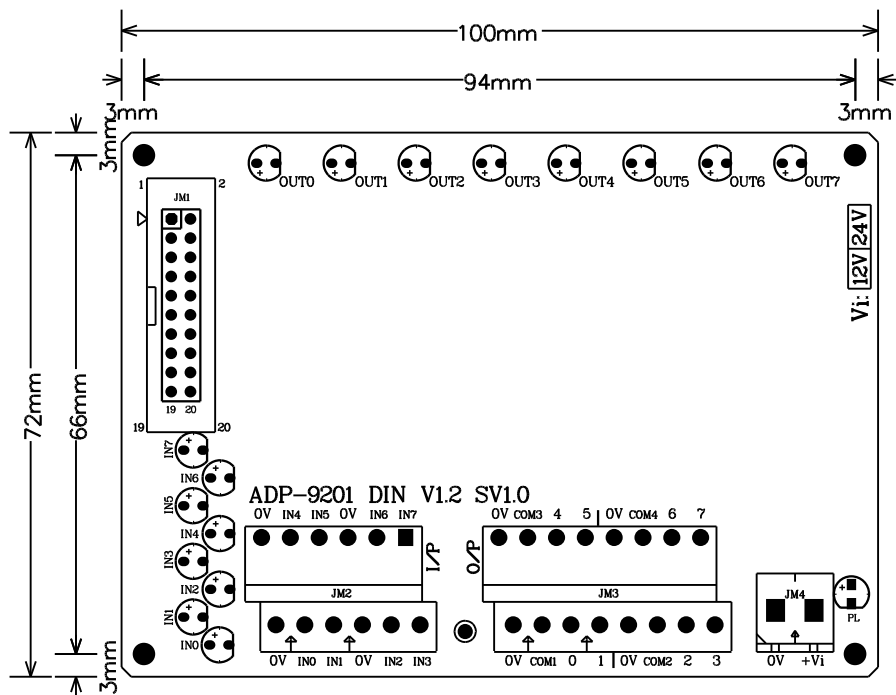

4.4 JS51053 for ADP9201_JM1 20PM Din rail mounted dummy wiring board

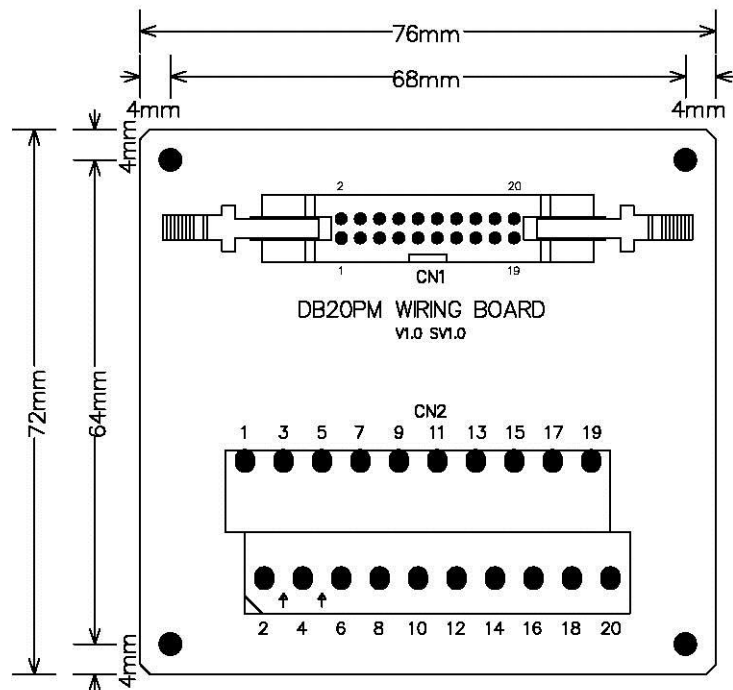

5. Pin definitions for main card connectors

5.1 JF1 pin definitions

PIN	DESCRIPTIONS		PIN	DESCRIPTIONS
1	+5Vin: 5V input from wiring board		11	EXTG: common of +5Vin
2	+5Vin: 5V input from wiring board		12	EXTG: common of +5Vin
3	A+: phase A+ input		13	A-: phase A- input
4	B+: phase B+ input		14	B-: phase B- input
5	Z+: phase Z+ input		15	Z-: phase Z- input
6	CLR_IN+: clear+ input		16	CLR_IN-: clear- input
7	NC		17	NC
8	HOME: home limit switch input		18	NC
9	NC		19	CMP_OUT: compare equal output
10	NC		20	NC

5.2 ADP9201_JM1 pin definitions

PIN	Descriptions		PIN	Descriptions
1	EXT_IN00 (compare out gate input)		2	EXT_OUT00
3	EXT_IN01		4	EXT_OUT01
5	EXT_IN02		6	EXT_OUT02
7	EXT_IN03		8	EXT_OUT03
9	EXT_IN04		10	EXT_OUT04
11	EXT_IN05		12	EXT_OUT05
13	EXT_IN06		14	EXT_OUT06
15	EXT_IN07		16	EXT_OUT07
17	EXTG		18	EXTG
19	+24Ve		20	+24Ve

6. I/O Interface diagram

6.1 JF1 ADP3101DIN

6.1.1 Input diagram

Type1 input: Differential

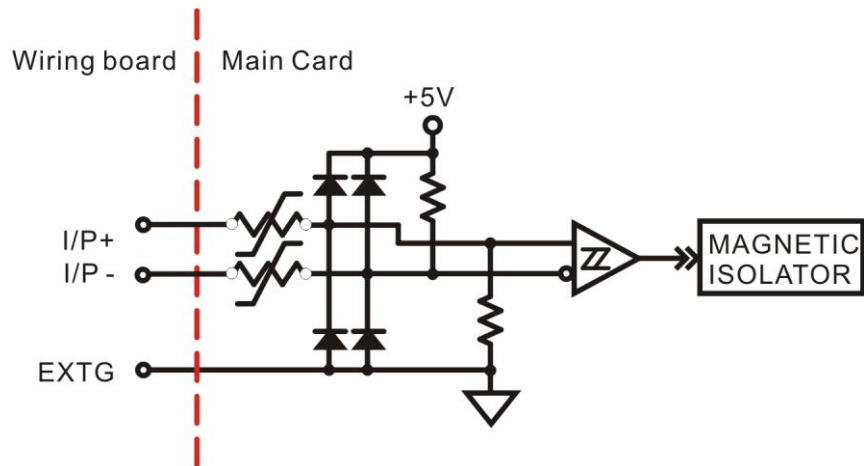

For A+/A-, B+/B-, C+/C-, CLR_IN+/CLR_IN-

Type2 input : Home

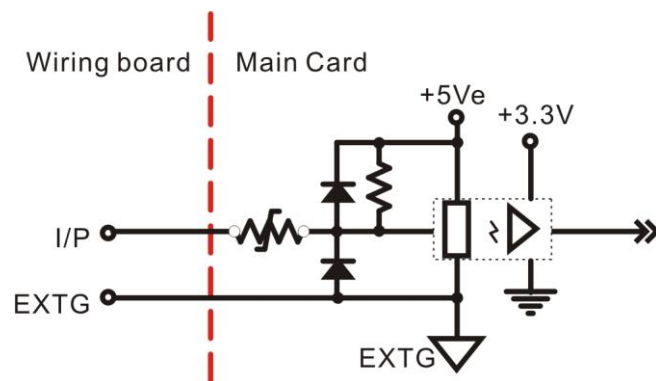

For Home

6.1.2 Output diagram

Type1 output :

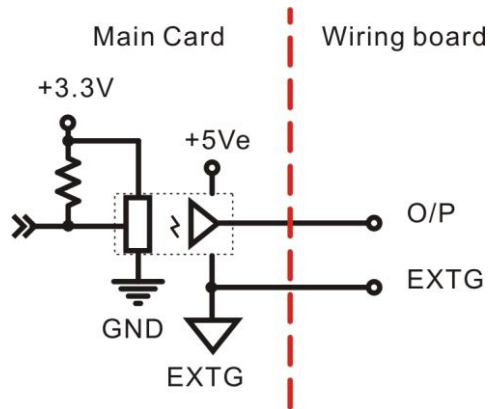

For compare equal output

6.2 ADP9201_JM1 ADP9201DIN

6.2.1 Input diagram

Type 1 Input:

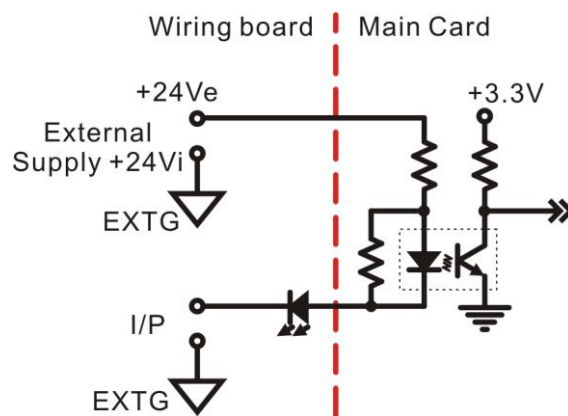

For IN00~IN07

6.2.2 Output diagram

Type 1 output : (PMOS)

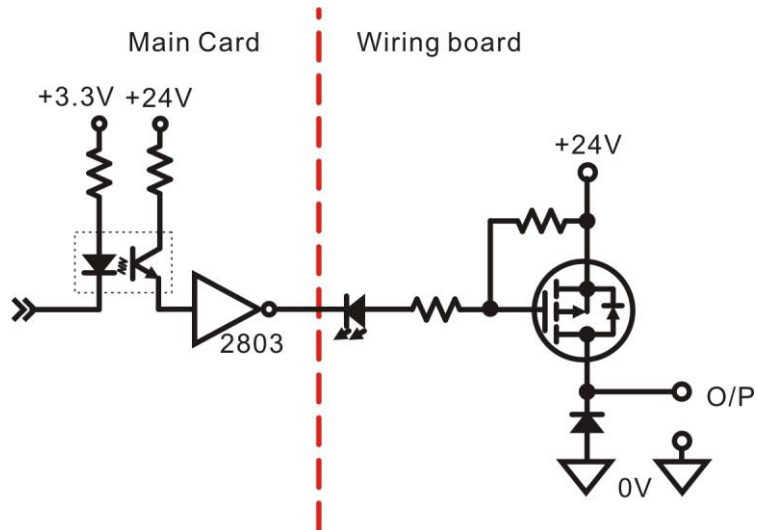

For OUT00~OUT07

Type 2 output : (Relay)

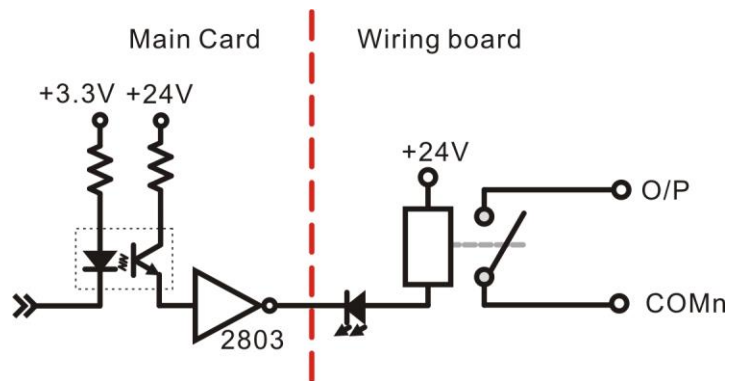

For OUT00~OUT07

Type 3 output : (SSR)

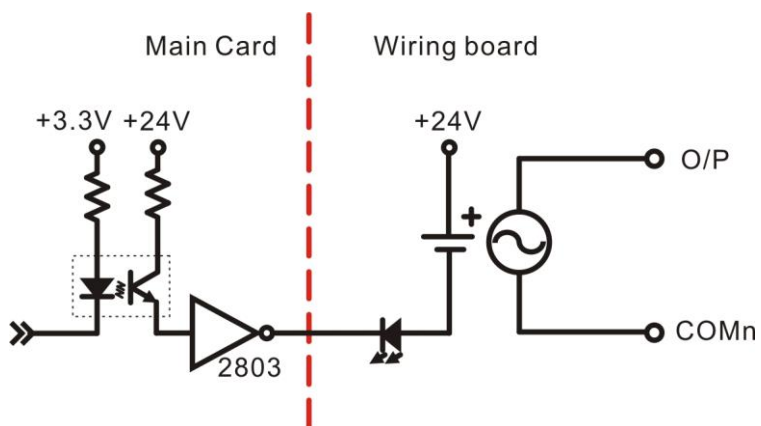

For OUT00~OUT07

7. Using wiring board

The matched wiring board provides easy interfacing between under control devices and the main control card. For different kind of under control devices, you can choose the wiring board of different interface type or just jump the selection jumper (if the wiring board have optional jumper selection).

7.1 ADP3101DIN wiring board

The ADP3101DIN wiring board is used for quadrature related functions, it can be set as differential input or single end input by jumper setting.

JP1		JP2	
1-2 short	2-3 short	1-2 short	2-3 short
Differential input	Single end input	Differential input	Single end input
Use A+,A-, B+,B- Z+,Z-	Use A+,B+,Z+. Leave others unconnected	Use CLR+,CLR-	Use CLR+ only, leave CLR- unconnected

Jumper settings of ADP3101DIN wiring board

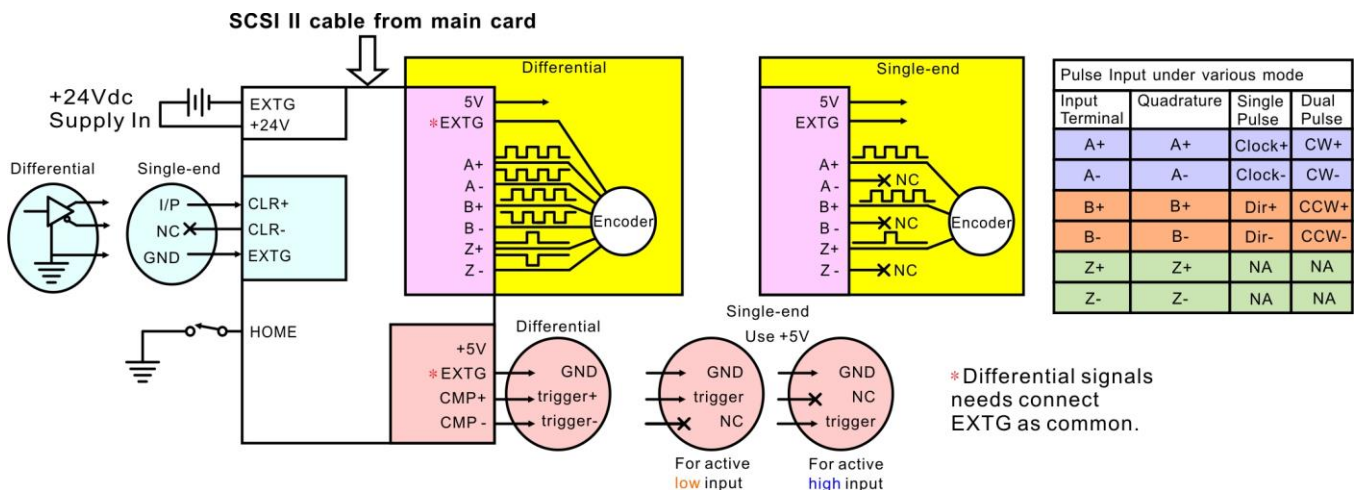

Sample wiring of ADP3101DIN

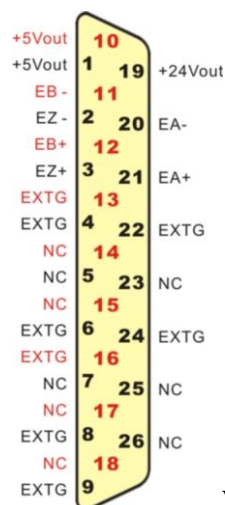

Wiring board DB26 specific connector

7.2 ADP9201DIN wiring board

The ADP9201DIN wiring board is used for general purpose digital I/O, there are 3 output types can choose. The following diagram are sample wiring method for different output types.

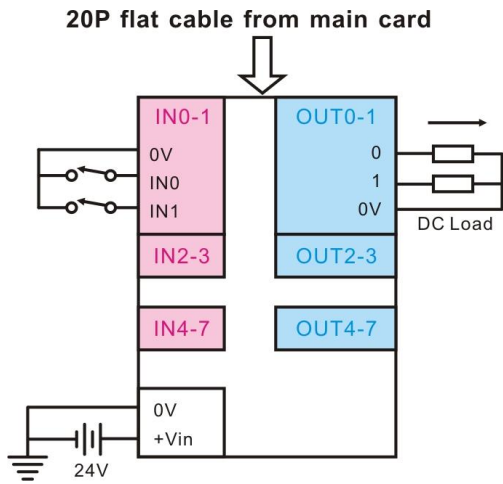

wiring board with PMOS output

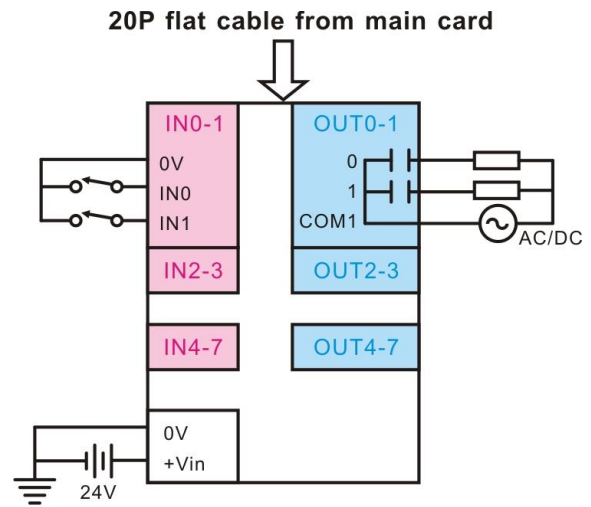

wiring board with Relay output

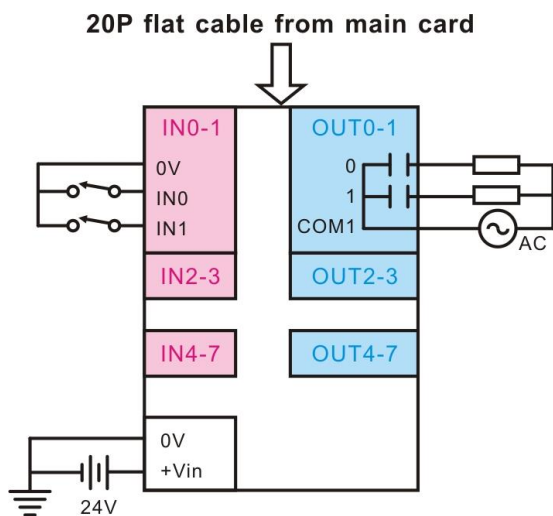

wiring board with SSR output

8. Main card hardware settings

8.1 Card ID setting

Since PCI cards have plug and play function, the card ID is required for programmer to identify which card he/she will control without knowing the physical address assigned by the Windows. A 4 bits rotary switch for extinguishing the 16 identical card. Do not select the same card ID number, if you use more than one same type card in your system.

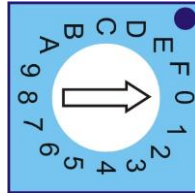

8.2 JP1 warm reset jumper

Output relay contact type setting (JP1)	
Reset output after warm reset	Keep output after warm reset

9. Applications

- For counting pulses on the fly, such as:
 - Encoder on various kinds of servo motor
 - Encoder on DC/AC motor
 - Optical scale output signal
 - Magnetic linear scale output
 - Timing disc
 - Revolution sprocket
 - Proximity sensor/detector with relative motion
 - Timer counter
- Compare position on the fly
- Pulse signal receiver /display
- X-Y Table linear Scale F/B

10. Ordering information

<u>PRODUCT</u>	<u>DESCRIPTIONS</u>
LSI3101	magnetic isolated one-axis Quadrature Encoder Counter Card (up to 8MHz quadrature input)
LSI3101A	magnetic isolated one-axis Quadrature Encoder Counter Card (up to 16MHz quadrature input)
ADP3101DIN	DIN rail mounted wiring board for LSI3101/3181/3188 quadrature counter related function.
M262020150	20-pin SCSI-II cable 1.5M
M262020300	20-pin SCSI-II cable 3.0M
ADP9201DIN(P)	DIN rail mounted wiring board for general digital I/O, PMOS out
ADP9201DIN(R)	DIN rail mounted wiring board for general digital I/O, relay out
ADP9201DIN(S)	DIN rail mounted wiring board for general digital I/O, SSR out
JS51053	DIN rail dummy wiring board for general digital I/O, Transistor out
M23207	20-pin flat cable 1.5M
M23209	20-pin flat cable 3.0M