



# Bridging the Gap between Real World and Computer

## Mokon-K Servo Driver



### Features

- ▶ Embedded floating point DSP
- ▶ High bandwidth and high response
- ▶ Easy servo parameters setting via RS-232 communication with KSDT software or build-in operator's panel
- ▶ Selection of electronic gear from I/O signal or parameter
- ▶ On the fly change of torque, speed and position mode
- ▶ Multi-purpose type command input to support most of motion control applications.

### Ordering Information

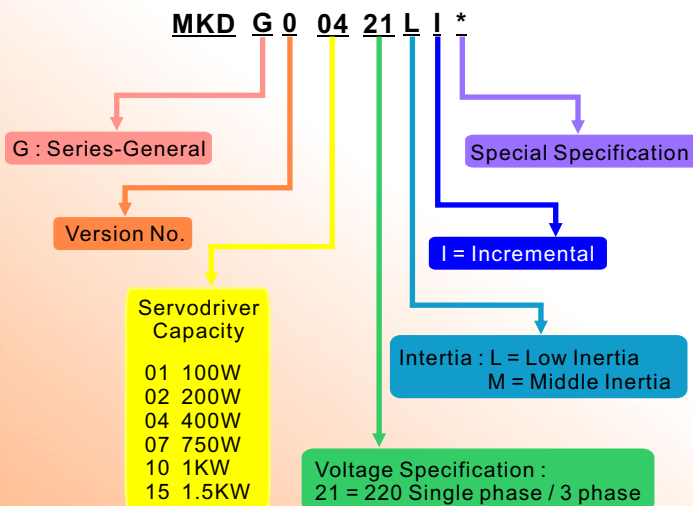

### Specifications

- ▶ System Overload capacity : 150% 1min
- ▶ Discharge Transistor : integrated
- ▶ Protective Function : Over Current, Over Voltage, Low Voltage, Over Load, Over Temperature, Encoder Error, Over Speed
- ▶ Feedback Output : parameter programmable
- ▶ Heat-Dissipation Method : Natural ventilation

#### Speed Control:

- ▶ Control Method : Sine PWM Current Control
- ▶ Control Ratio : 3000:1
- ▶ Speed Command : 0~10V/0~Rated Speed
- ▶ Acceleration and Deceleration Method : S type or Linear type profile
- ▶ Torque Limit : 0~10V/0~300%Max Torque

#### Position Control:

- ▶ Position command : A/B, CW/CCW, PULSE/DIR
- ▶ Position command Output bandwidth : Differential type : 2M Transistor type : 200K
- ▶ Position Command Resolution : 4x Installed encoder resolution
- ▶ In-Position setting range : 0 ~ ±32767 pulse
- ▶ Electronic Gear Ratio : 1~2<sup>17</sup>
- ▶ Torque Limit : 0~10V/0~300%Max Torque

#### Torque Control:

- ▶ Torque command : 0~10V/300% Rated Torque
- ▶ Speed Limit : Internal Torque Speed limited or limit from External Analog Speed Limit Command

#### Environment:

- ▶ Storage Temperature : -20 °C ~ 65 °C
- ▶ Operation Temperature : 0 °C ~ 40 °C
- ▶ Humidity : Humidity below 90% RH, non-condensing
- ▶ Altitude : Sea Level below 1000M
- ▶ Vibration : Below < 5m/s



# Bridging the Gap between Real World and Computer

## Dimensions

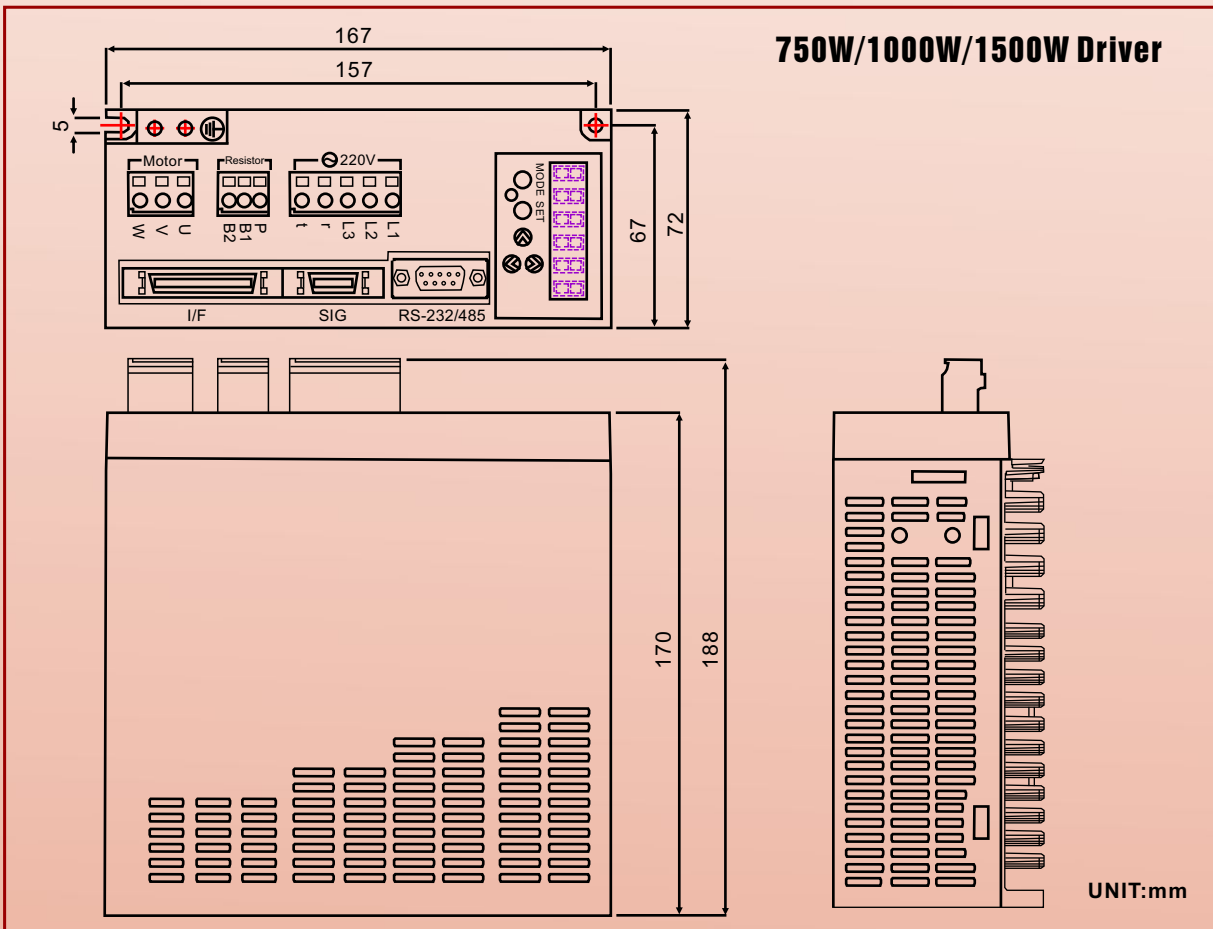
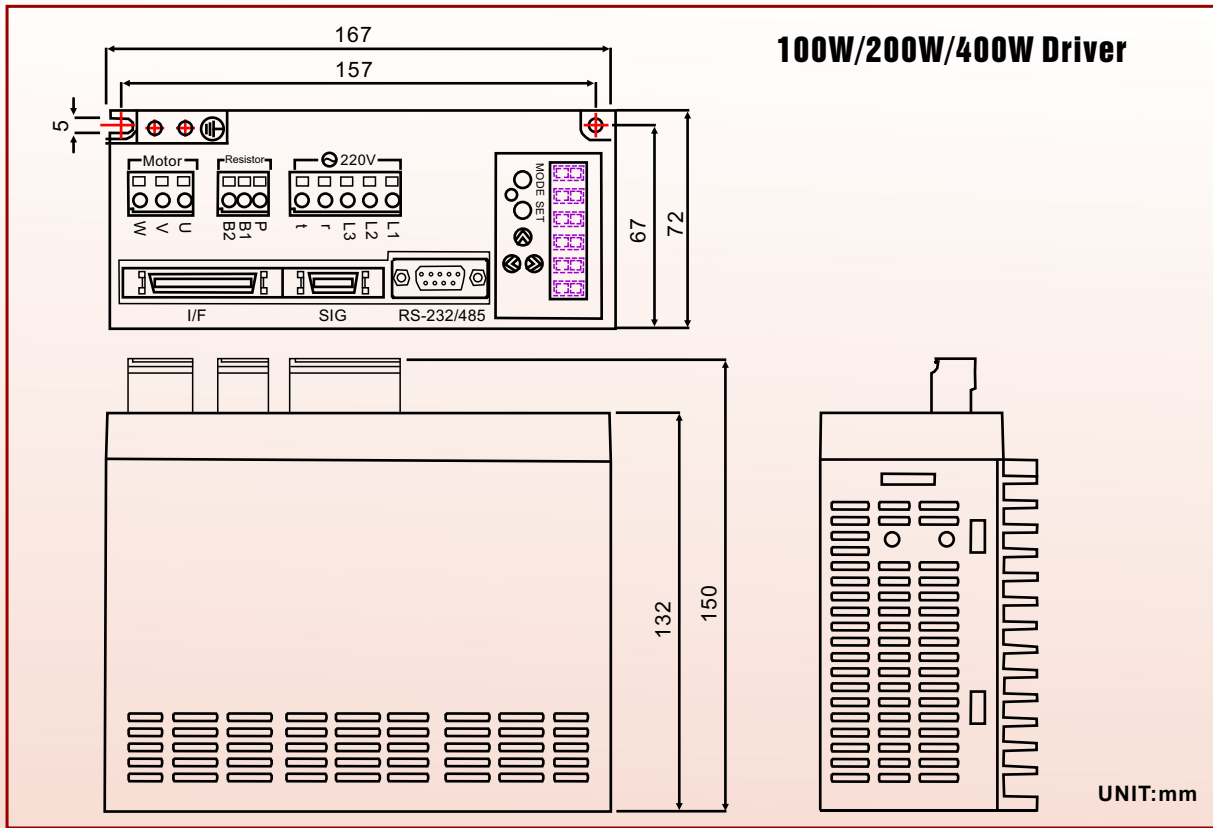



# Bridging the Gap between Real World and Computer

## Control Interface

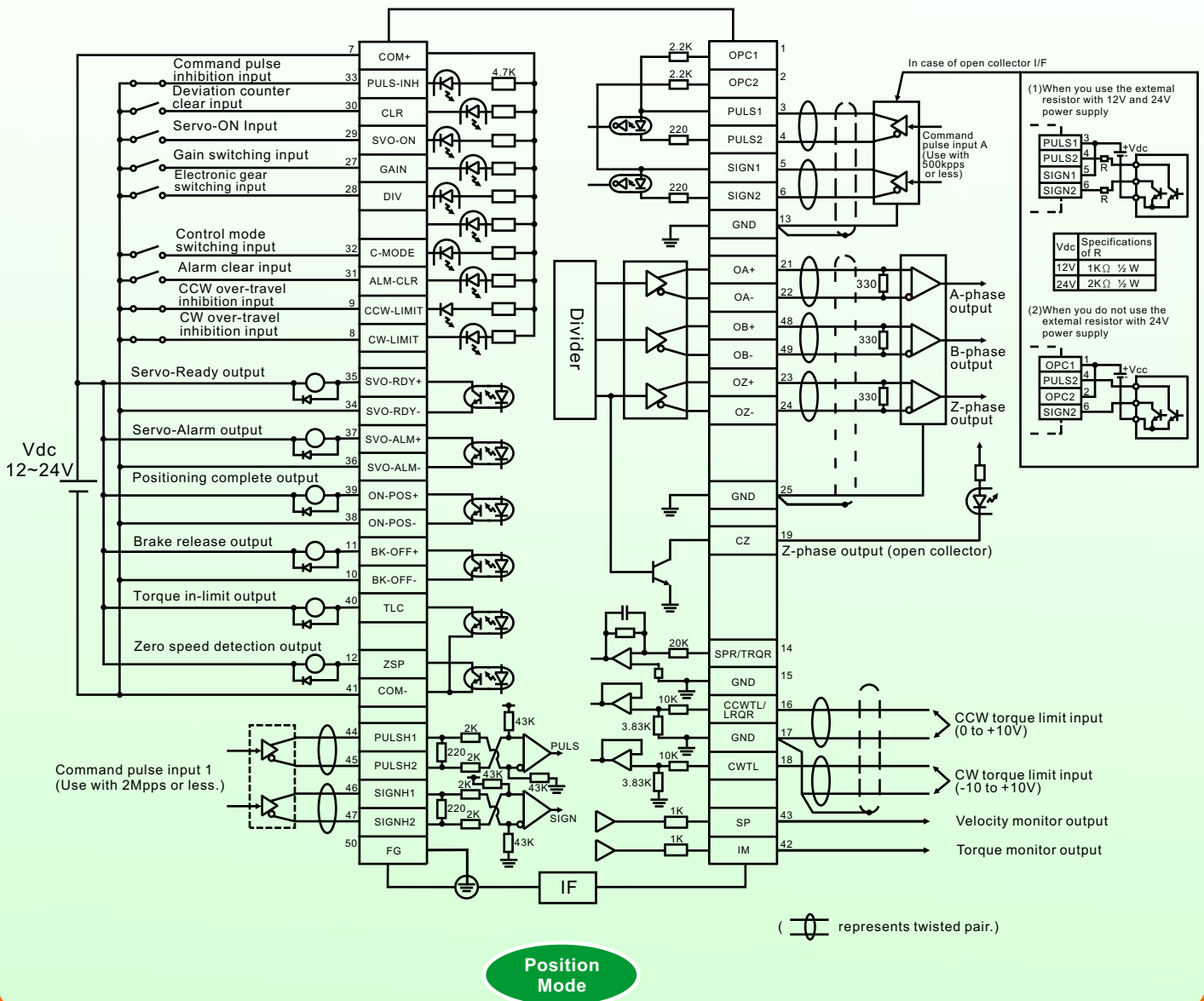

## Note



# Bridging the Gap between Real World and Computer

## Control Interface

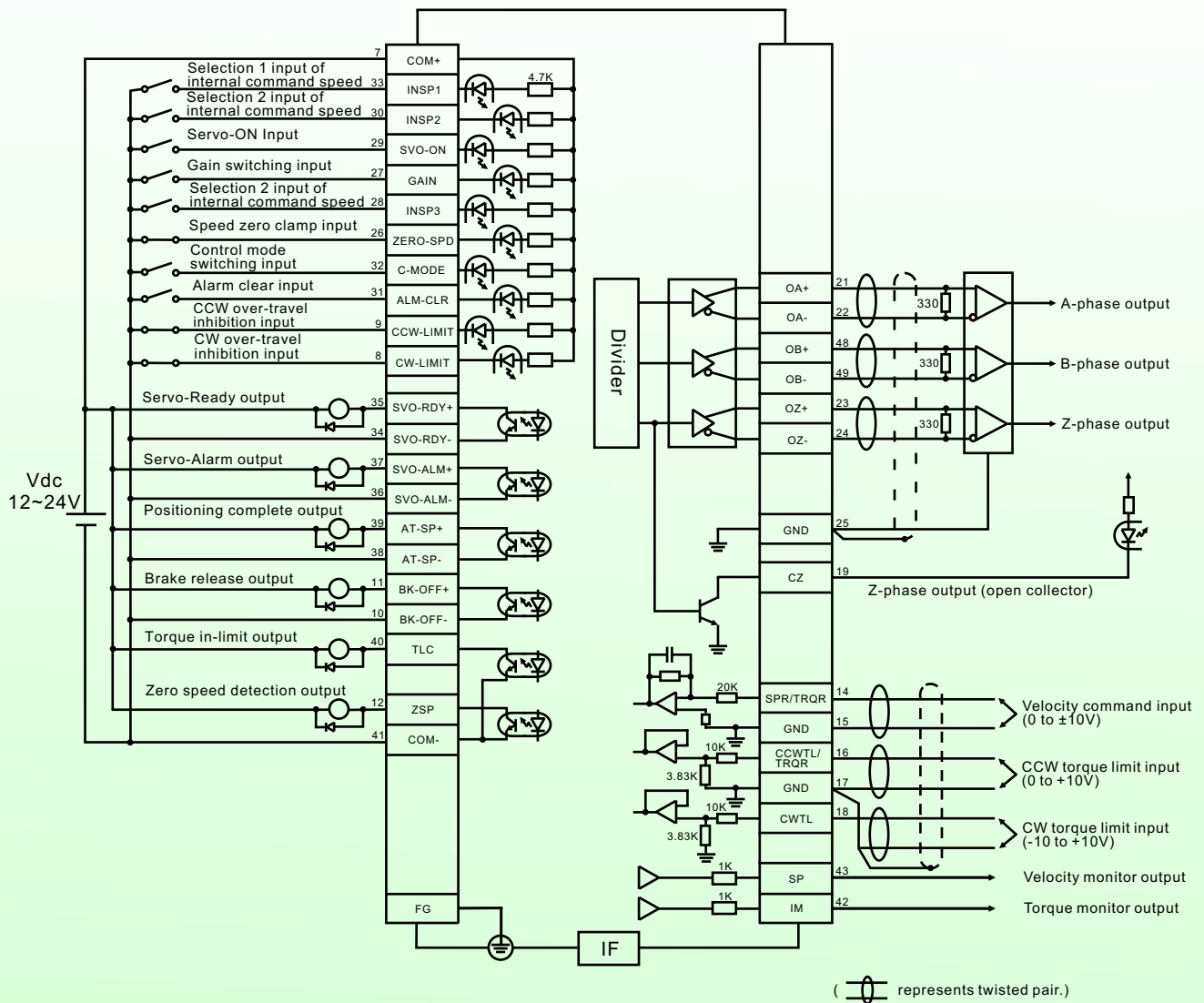

## Note



# Bridging the Gap between Real World and Computer

## Control Interface

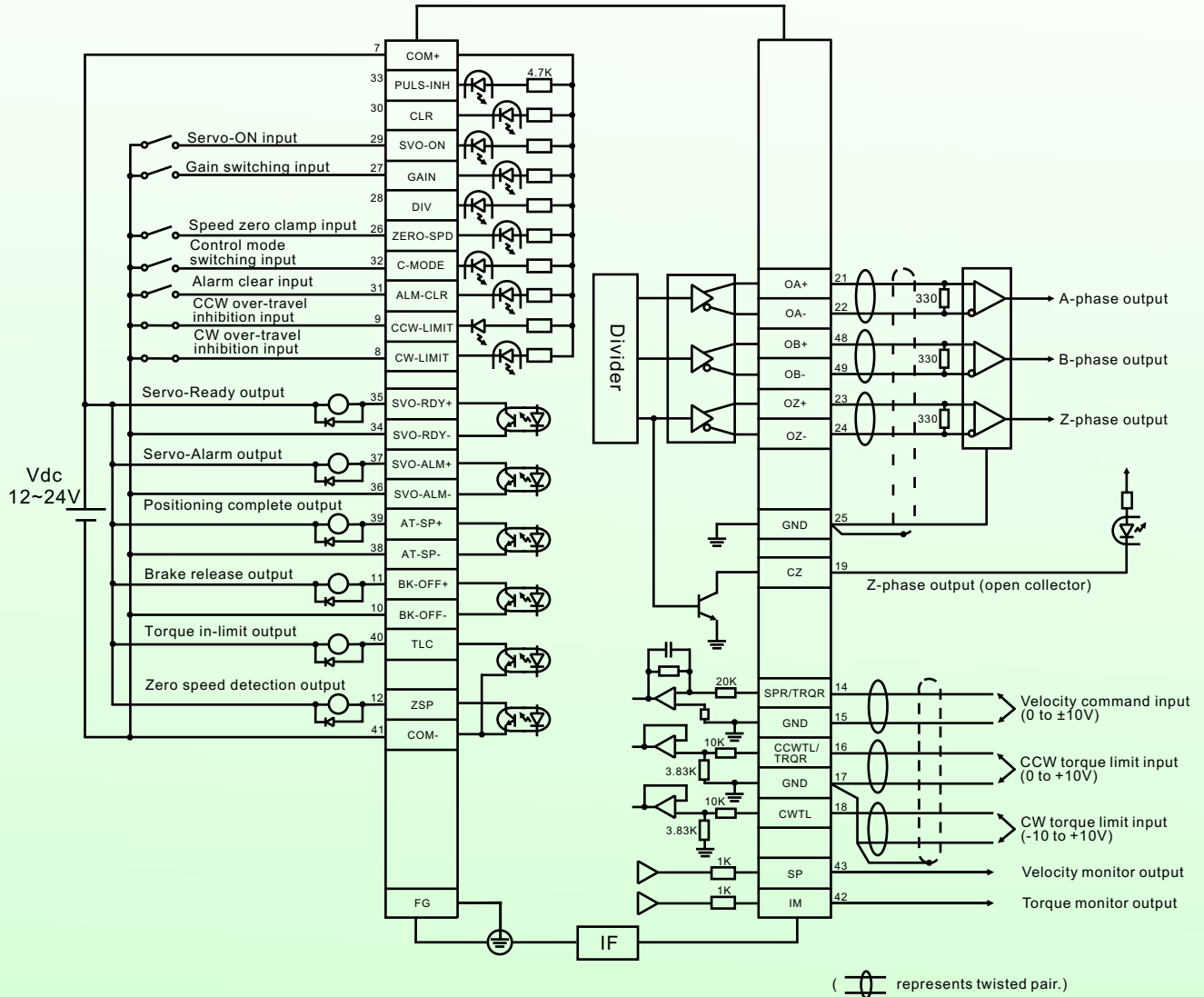

Torque Mode

## Note