



# Bridging the Gap between Real World and Computer

## Mokon-K Servo Motor



### Reference Formulas

$$P(W) = T(N\cdot m) \times \omega(\text{rad/s})$$

$$P(W) = T(\text{kgf}\cdot\text{m}) \times \omega(\text{rad/s}) \times 9.8(\text{N/kgf})$$

$$T(N\cdot m) = J(\text{kg}\cdot\text{m}^2) \times \alpha(\text{rad/s}^2)$$

$$1\text{hp}(\text{British}) = 550\text{lb}\cdot\text{ft/s} = 745.7\text{W}$$

$$1\text{hp}(\text{metric}) = 75\text{kgf}\cdot\text{m} = 735.5\text{W}$$

$$1\text{kg} = 10^3\text{g} = 2.2046\text{lb} = 35.274\text{oz}$$

$$1\text{N} = 0.102\text{kp} = 0.102\text{kg} = 102\text{g} = 0.2248\text{lb} = 3.5968\text{oz}$$

$$1\text{Nm} = 0.102\text{kpm} = 0.738\text{lb}\cdot\text{ft} = 141.61\text{oz}\cdot\text{in} = 10.2\text{Kg}\cdot\text{cm}$$

$$1\text{kg}\cdot\text{m}^2 = 1.02 \times 10^4 \text{gm}\cdot\text{cm}\cdot\text{sec}^2 = 23.73\text{lb}\cdot\text{ft}^2 = 0.737\text{ft}\cdot\text{lb}\cdot\text{sec}^2 = 5.467 \times 10^4 \text{oz}\cdot\text{in}^2 = 141.7\text{oz}\cdot\text{in}\cdot\text{sec}^2$$

### 200V Series

Model Number	MKA01	MKA02	MKA04	MKA07	MKA10	MKA15
Rated Power (W)	100 W	200 W	400 W	750 W	1KW	1.5KW
Matched Driver	MKDG001 21	MKDG002 21	MKDG004 21	MKDG007 21	MKDG010 21	MKDG015 21
Rated Torque (N-cm)	32	65	130	240	480	720
Instantaneous max. Torque (N-cm)	96	195	390	720	1440	2160
Rated Speed (RPM)	3000			2000		
Rated Current (A)	1.3	1.72	2.82	5.4	5.4	8
Instantaneous max. Current (A)	3.9	5.16	8.46	16.2	16.2	24
Rotor Inertia (Kg-cm <sup>2</sup> )	0.031 2	0.172	0.3	0.8	11.7	17.6
Encoder (ppr)	2500					
Weight (Kgf)	0.66	1.16	1.55	2.63	7.39	9.24
Operating Ambient Environment	0 °C ~ +40 °C Below 20 ~ 90% RH (non-condensation)					
Storage Ambient Environment	-20 °C ~ +80 °C Below 20 ~ 90% RH (non-condensation)					
Dimension	100 W	200 W	400 W	750 W	1KW	1.5KW
Optional Brake	Rated Voltage	-	84V	90V	-	-
	Static Friction Torque (N-cm)	-	4	4	-	-
	Inertial (kg-cm <sup>2</sup> )	-	0.172	0.3	-	-
	Rated Current (A)	-	1.72	2.82	-	-
	Weight (kgf)	-	1.56	1.98	-	-



# Bridging the Gap between Real World and Computer

## Ordering Information

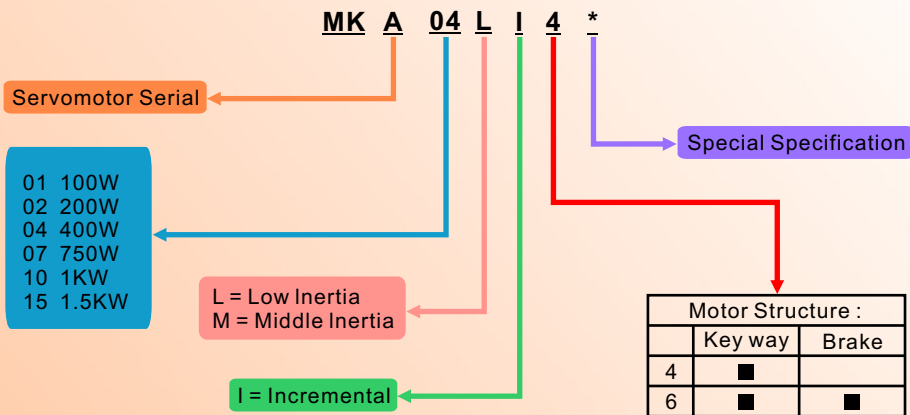

## Torque Speed Characteristics

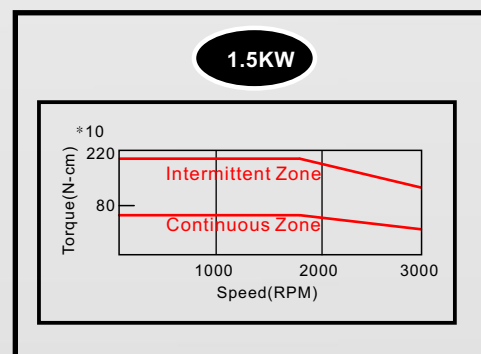
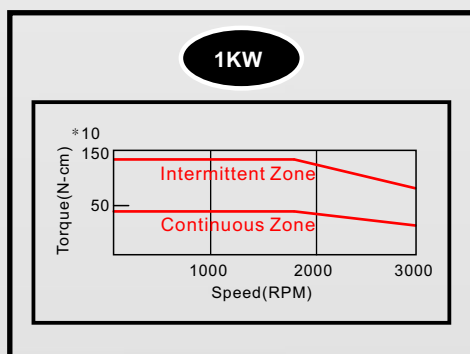
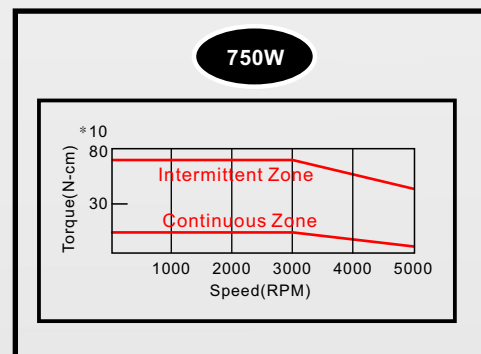
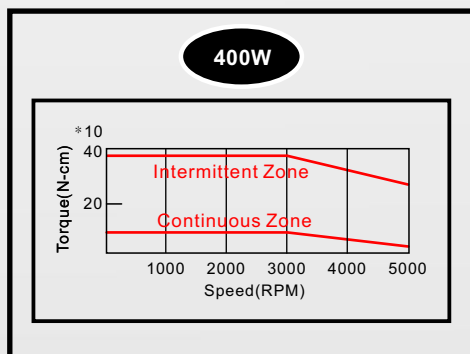
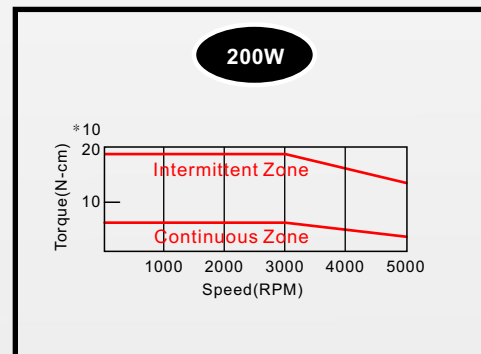
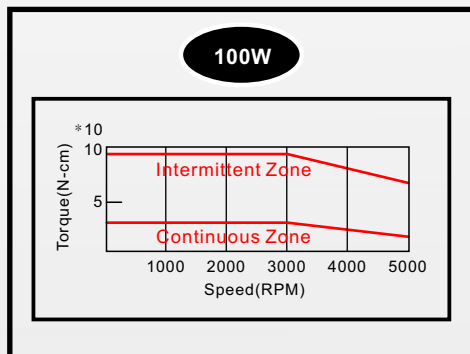



# Bridging the Gap between Real World and Computer

## Dimensions

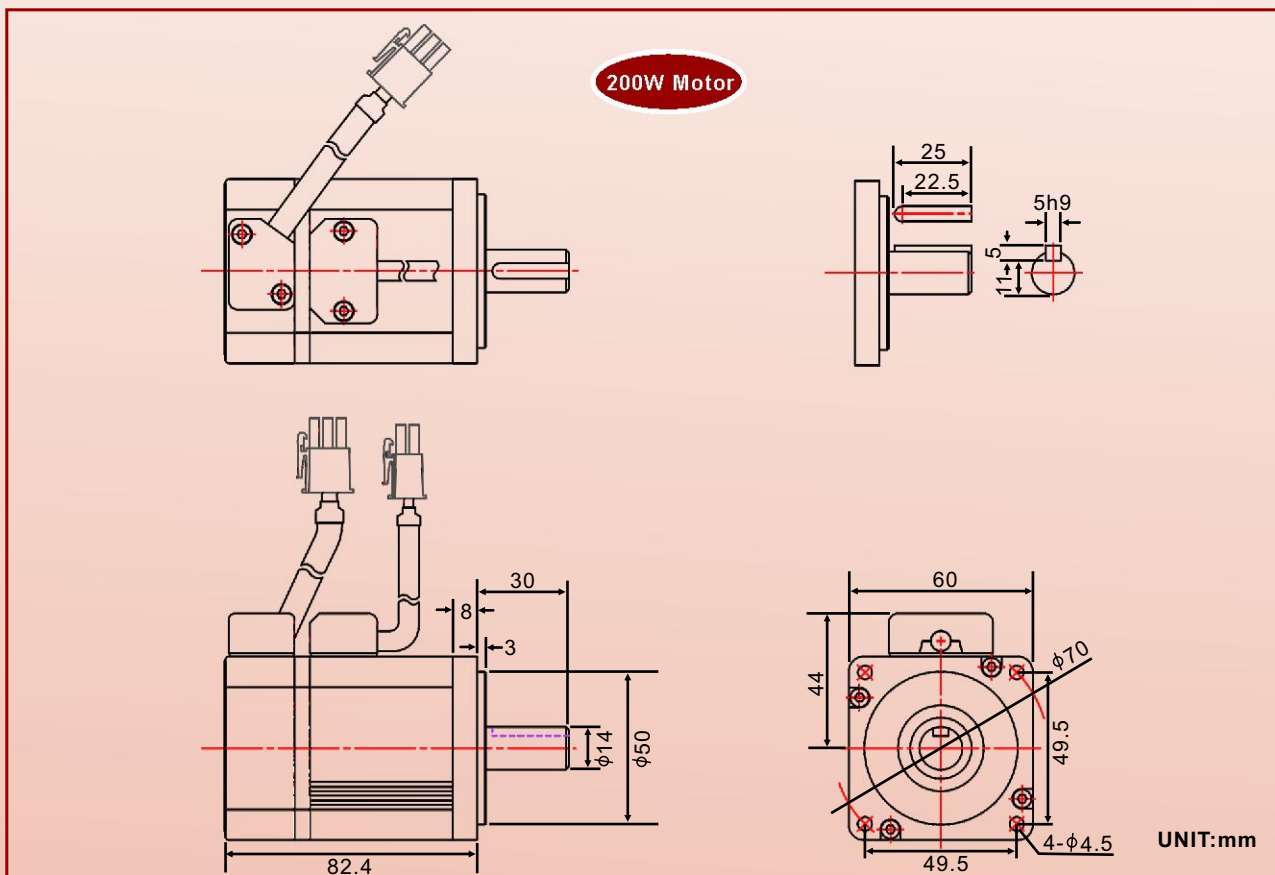
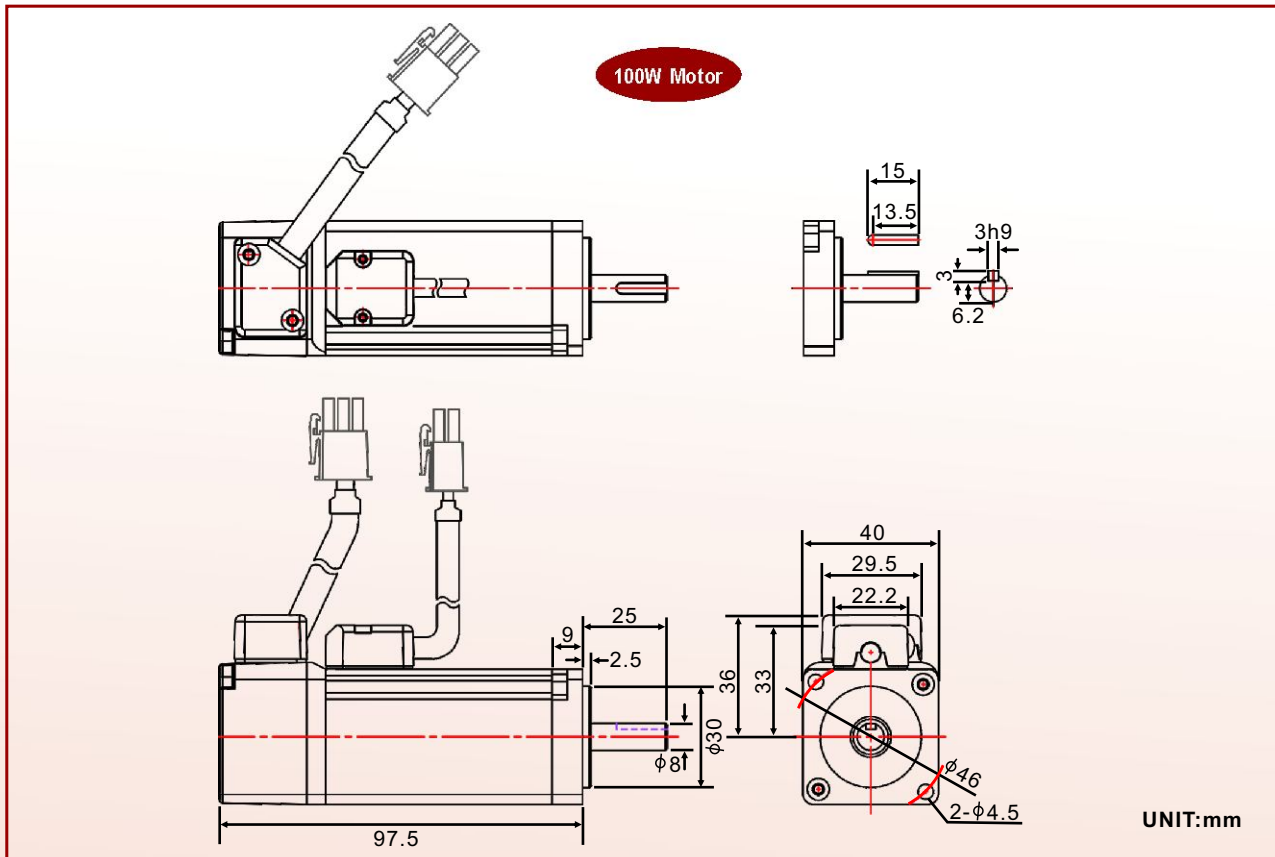



# Bridging the Gap between Real World and Computer

## Dimensions

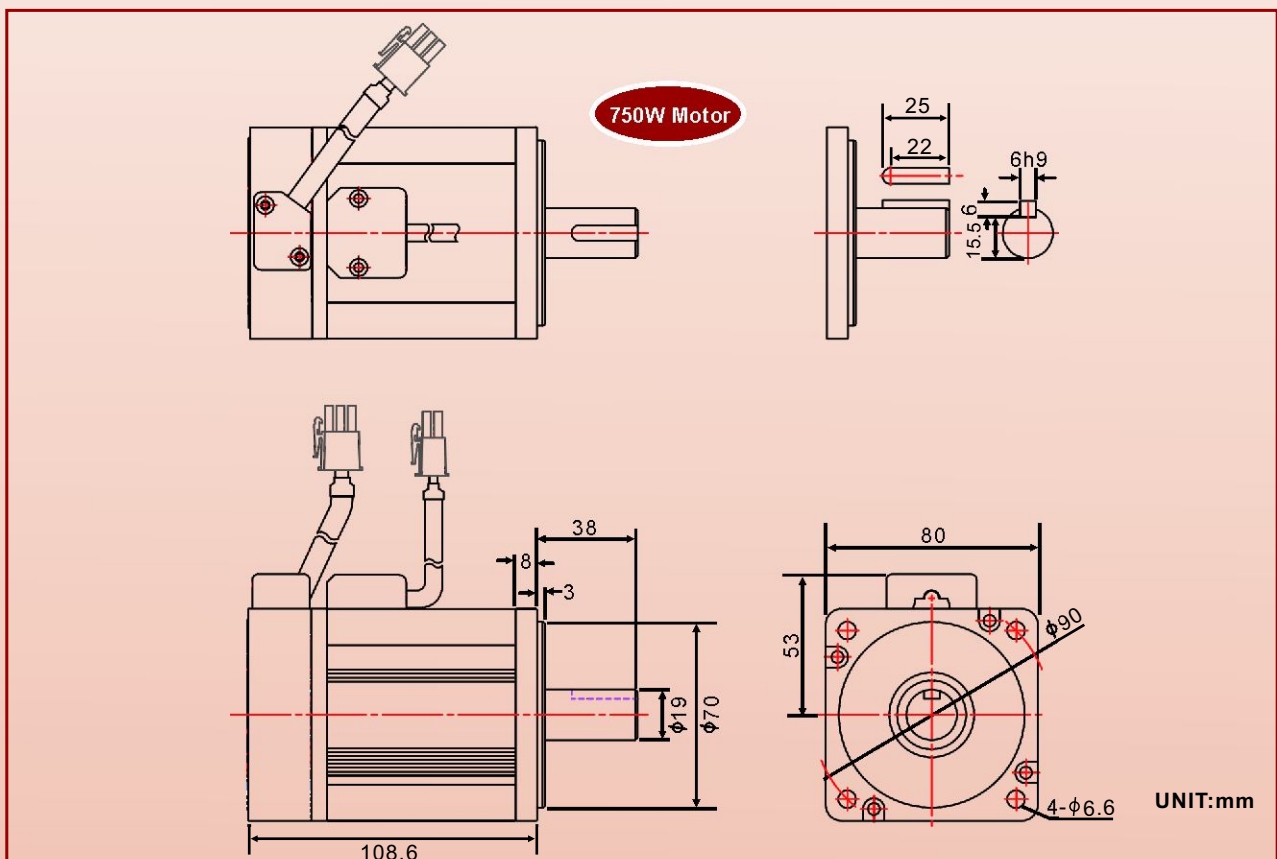
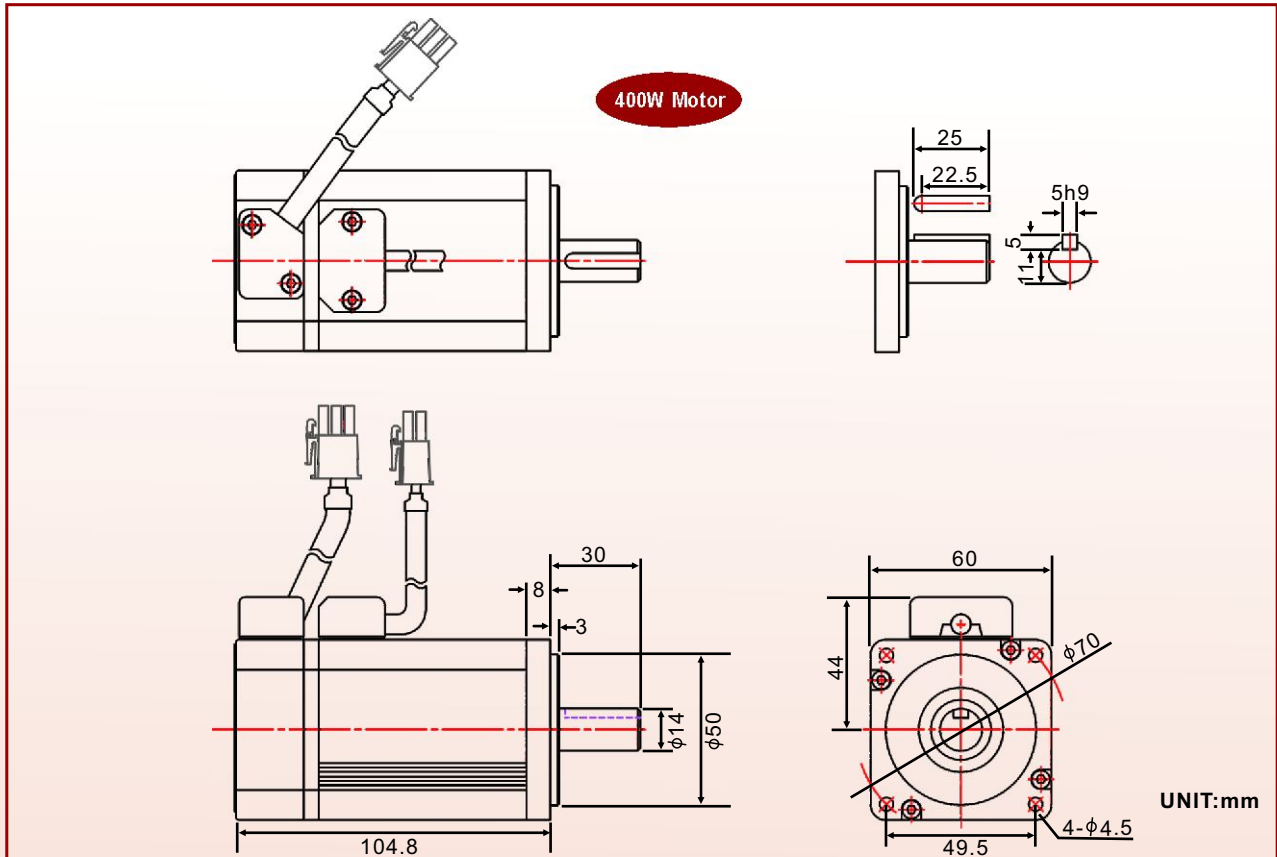



# Bridging the Gap between Real World and Computer

## Dimensions

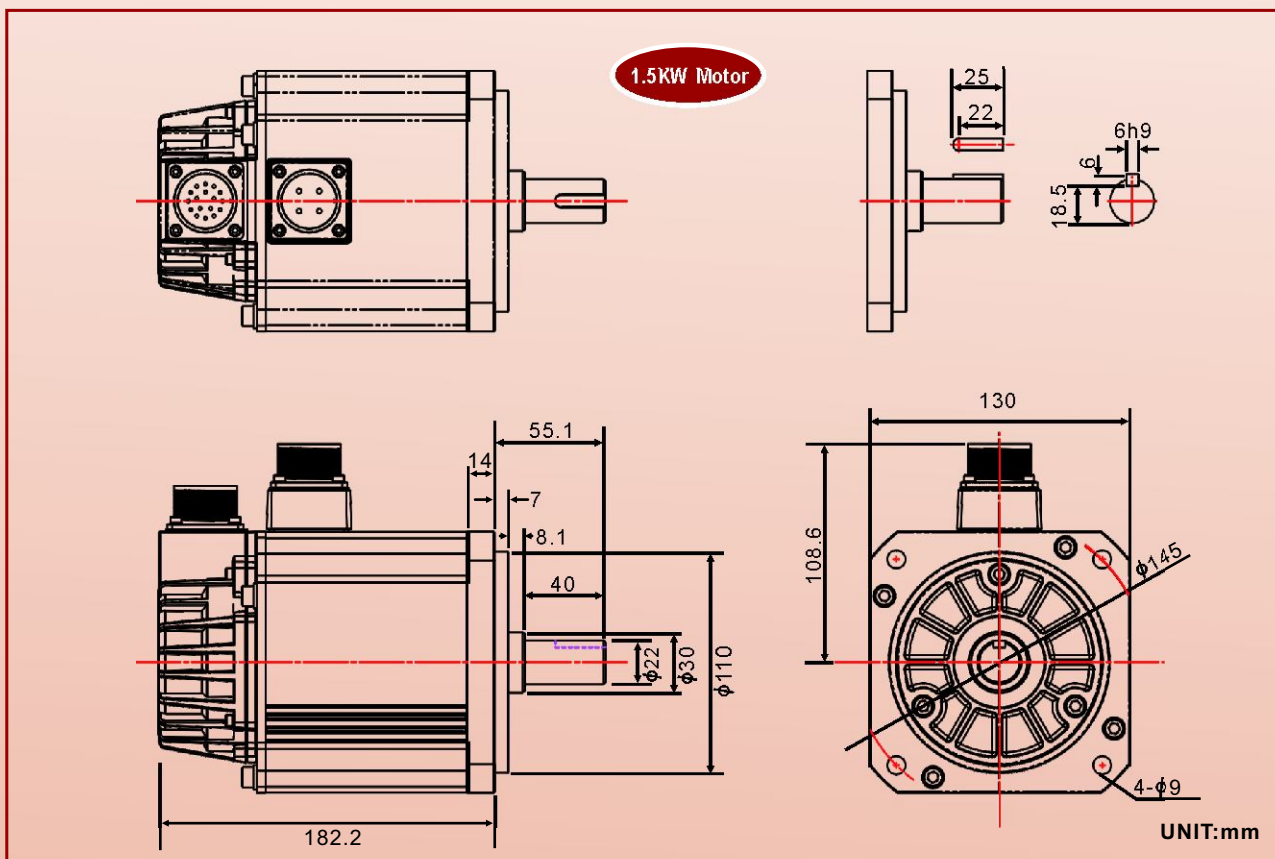
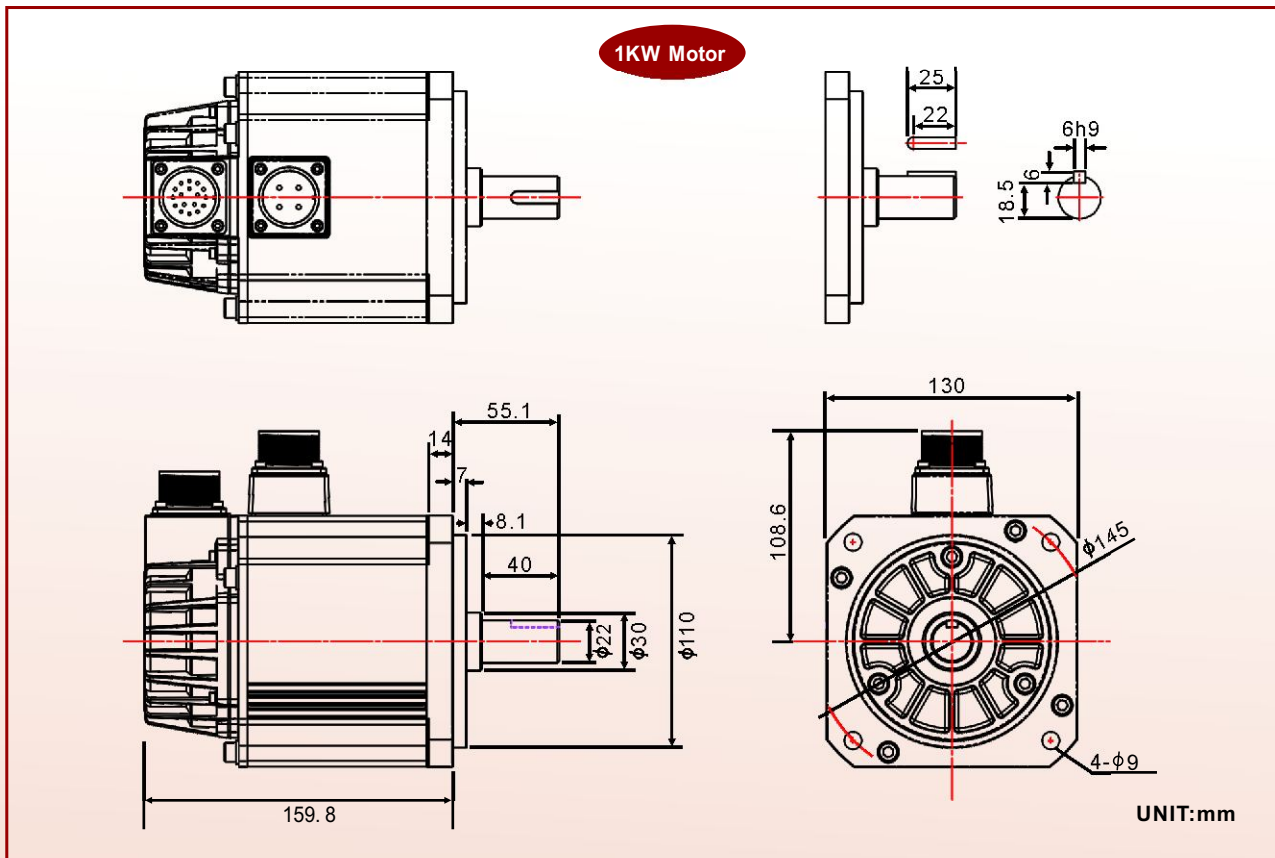



# Bridging the Gap between Real World and Computer

## Dimensions

