

MPC3034A

4-Axis Motion Control Card

User's Manual (V1.0)

健昇科技股份有限公司

JS AUTOMATION CORP.

新北市汐止區中興路 100 號 6 樓
6F., No.100, Zhongxing Rd.,
Xizhi Dist., New Taipei City, Taiwan
TEL : +886-2-2647-6936
FAX : +886-2-2647-6940
<http://www.automation.com.tw>
<http://www.automation-js.com/>
E-mail : control.cards@automation.com.tw

Correction record

Version	Record
1.0	MPC3034A compatible with old version MPC3034

Contents

1.	Forward.....	4
2.	Features.....	5
2.1	Main card.....	5
2.2	Din rail mounted wiring board.....	5
3.	Specifications.....	6
3.1	MPC3034A Main card.....	6
3.2	Din rail mounted wiring board.....	7
4.	Layout and dimension.....	8
4.1	MPC3034A Main card.....	8
4.2	ADP3024DIN for JF1,2 Din rail mounted wiring board.....	9
4.3	JS51050 for JM3 25PM Din rail mounted dummy wiring board.....	9
5.	Pin definitions.....	10
5.1	JF1,JF2 Assignment / Definitions.....	10
5.2	JM1,JM2 Assignment / Definitions.....	12
5.3	JM3 Assignment / Definitions.....	12
6.	I/O interface diagram.....	13
6.1	JF1/2 ADP3024DIN.....	13
6.2	JM3 JS51050.....	16
7.	External wiring diagram.....	17
8.	Hardware settings.....	18
8.1	Card ID setting.....	18
8.2	Polarity setting for over-travel limit switch.....	18
8.3	JP1 Jumper setting.....	18
9.	Applications.....	19
10.	Wiring diagram examples.....	20
10.1	The wiring diagram for MPC3034A wiring board to panasonic MINAS-A driver.....	20
10.2	The wiring diagram for MPC3034A wiring board to panasonic MINAS MSD*** driver....	20
10.3	The wiring diagram for MPC3034A wiring board to ESD servo driver.....	21
10.4	The wiring diagram for MPC3034A wiring board to Moda servo driver.....	21
10.5	The wiring diagram for MPC3034A wiring board to YASKAWA servo driver.....	22
10.6	The wiring diagram for MPC3034A wiring board to Mokon / YPV servo driver.....	22
10.7	The wiring diagram for MPC3034A wiring board to Mokon / YJD servo driver.....	23
10.8	The wiring diagram for MPC3034A wiring board to MITSUBISHI J2-SUPER servo driver.....	24
10.9	The wiring diagram for MPC3034A wiring board to YAMAHA SRCP servo driver.....	24
10.10	The wiring diagram for MPC3034A wiring board to Delta ASDA-B servo driver.....	25
10.11	The wiring diagram for MPC3034A wiring board to Delta ASDA-B2 servo driver.....	25
11.	Ordering information.....	26

Notes on hardware installation

Please follow step by step as you are installing the control cards.

1. Be sure your system is power off.
2. Be sure your external power supply for the wiring board is power off.
3. Plug your control card in slot, and make sure the golden fingers are put in right contacts.
4. Fasten the screw to fix the card.
5. Connect the cable between the card and wiring board.
6. Connect the external power supply for the wiring board.
7. Recheck everything is OK before system power on.
8. External power on.

Congratulation! You have it.

For more detail of step by step installation guide, please refer the file “installation.pdf” on the CD come with the product or register as a member of our user’s club at:

<http://automation.com.tw/>

to download the complementary documents.

1. **Forward**

Thank you for your selection of 4 axis motion control card. This card adopt the ASIC chip with complex motion functions including point to point, linear and circular interpolation, linear and s-curve acceleration/deceleration and several miscellaneous functions. Dll's of various functions will save you a lot of time in the motion related projects.

Our other motion control products:

- MPC3024A 4 axes linear/circular/point to point (standard function) motion control card (PCI bus)
- MPC3024AC 4-axis linear/circular/point to point (standard function) motion control card with Pulse referenced PI closed loop control (PCI bus)
- MPC3028A 8 axes linear/circular/point to point (standard function) motion control card (PCI bus)
- MPC3042A 2 axes linear/circular/point to point (standard function) motion control card with Pulse Referenced PI Control (PCI bus)
- MPC3042AL 2 axes linear/circular/point to point (standard function) motion control card (PCI bus)
- MPC3035A 4 axes linear/circular/point to point (standard function) motion control card with advanced encoder counter function / with 2 8bit DA's motion control card (PCI bus)
- MPC3035AL 4 axes linear/circular/point to point (standard function) motion control card with advanced encoder counter function motion control card (PCI bus)

Any comment is welcome,

please visit our website

<http://www.automation.com.tw/>

<http://www.automation-js.com/> for the up to date information.

2. Features

2.1 Main card

- 2.1.1 4-axis servo/stepping motor control
- 2.1.2 4 28-bit up/down counter for incremental encoder
- 2.1.3 4 28-bit up/down counter for pulse handler input
- 2.1.4 Pulse output rate up to 6.55MHz
- 2.1.5 Pulse output options : OUT/DIR,CW/CCW
- 2.1.6 2~4 axes linear interpolation
- 2.1.7 Any 2 axes circular interpolation
- 2.1.8 S curve or T curve acceleration / deceleration in interpolation and positioning
- 2.1.9 Continuous interpolation
- 2.1.10 Speed change on the fly
- 2.1.11 Synchronized start motion
- 2.1.12 Position latch function
- 2.1.13 Simultaneously start/stop on multi-axes
- 2.1.14 Programmable interrupt conditions
- 2.1.15 Backlash compensation
- 2.1.16 Pulse handler function
- 2.1.17 Software limit switches protection
- 2.1.18 2 nibble configurable digital TTL I/O
- 2.1.19 Motion parameters change on the fly
- 2.1.20 Matched software FIFO for arbitrary curve motion

2.2 Din rail mounted wiring board

- 2.2.1 JS51050 dummy wiring board for JM3 pulse handler interface
- 2.2.2 ADP3024DIN wiring board for JF1,2 motion control interface

3. Specifications

3.1 MPC3034A Main card

Motion

- 3.1.1 Max pulse rate — 6,553,500 pps
- 3.1.2 Pulse output mode — Single phase: CLOCK,DIR
- 3.1.3 Dual phase — CW, CCW
- 3.1.4 Acceleration / Deceleration mode — linear ,S-curve mode
- 3.1.5 Homing mode — 14 types
- 3.1.6 Encoder up/down counter — 4 28bit counter
- 3.1.7 Pulse Handle up/down counter — 4 28 bit counter
- 3.1.8 Linear interpolation — any 2 up to 4 axis
- 3.1.9 Circular interpolation — any 2 axes

Digital I/O

- 3.1.10 Motion specific input — SRDY, ALM, LS+(EL+), LS-(EL-), SD, HOME(ORG), PCS, LTC per axis , EMG per card
- 3.1.11 Motion specific output — CMP,SVON,ERC,FIN per axis
- 3.1.12 General input — INP per axis
- 3.1.13 TTL I/O — 2 nibble configurable TTL I/O

General

- 3.1.14 Card ID — 16 locations set by rotary switch
- 3.1.15 Insulation resistance — 100 M Ω (min) at 1000Vdc
- 3.1.16 Isolation voltage — 2500Vac 1Min
- 3.1.17 I/O connector — 2 68pin female mini SCSI connector
- 3.1.18 External supply — DC 24 \pm 4V
- 3.1.19 Operation temperature — 0 to 70° C
- 3.1.20 Storage temperature — -20 to 80° C
- 3.1.21 Operation humidity — 5~95% RH, non-condensing
- 3.1.22 Dimensions — 175(W) * 122(H) mm , 6.9(W)*4.8(H)in

3.2 Din rail mounted wiring board

ADP3024DIN for JF1,2 motion control interface

- 3.2.1 Power Requirement — 24Vdc \pm 4Vdc
- 3.2.2 On Board Build-in s.p.s. — +5Vdc 500mA (max)
- 3.2.3 General input — 4 with LED indicator
- 3.2.4 Output capacity — 8 NMOS output, 1A continuous \cdot 120Vdc(max)
Option : 8 PMOS output, 1A continuous \cdot 24Vdc(max)
Option : 8 Relay output, 3A continuous \cdot 250Vac(max)
- 3.2.5 Connector — 2 68pin mini SCSI female connector for main card connection
- 3.2.6 Specific servo control connectors — 4 D-type 26p (1 per axis)
- 3.2.7 Operation temperature — 0 to 70° C
- 3.2.8 Operation humidity — RH5~95%, non-condensed
- 3.2.9 Dimension — ADP3024DIN(N) : 121(W) * 204(L) *47(H)mm;
4.8(W)*8.1(L)*1.9(H)in
ADP3024DIN(P) / (R) : 121(W) * 204(L) *45(H)mm
4.8(W)*8.1(L)*1.8(H)in

JS51050 for JM3 pulse handler interface

- 3.2.10 Connection cable — D-type 25P cable to connect main and wiring board
- 3.2.11 Dimension — 86(W)*79(L)*52(H)mm , 3.4(W)*3.2(L)*2.1(H)in

4. Layout and dimension

4.1 MPC3034A Main card

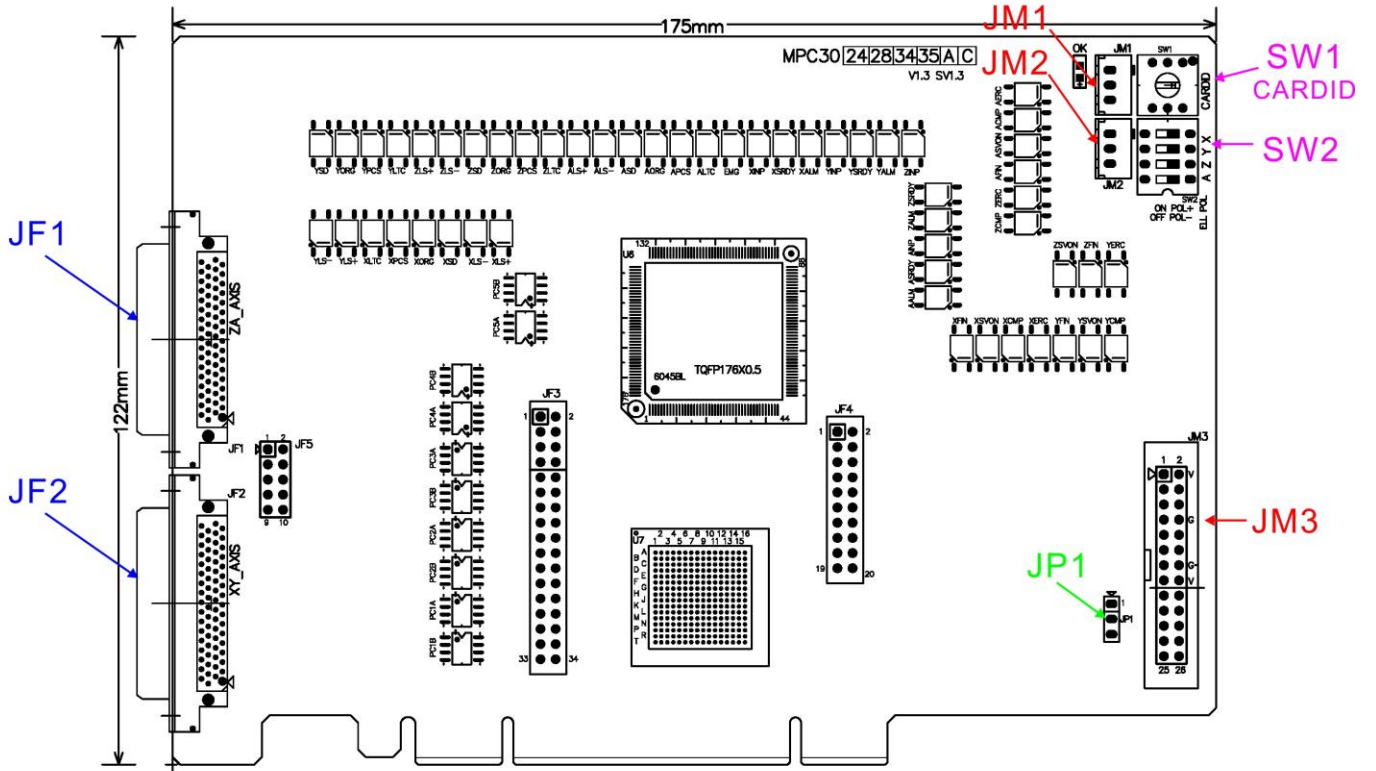

4.2 ADP3024DIN for JF1,2 Din rail mounted wiring board

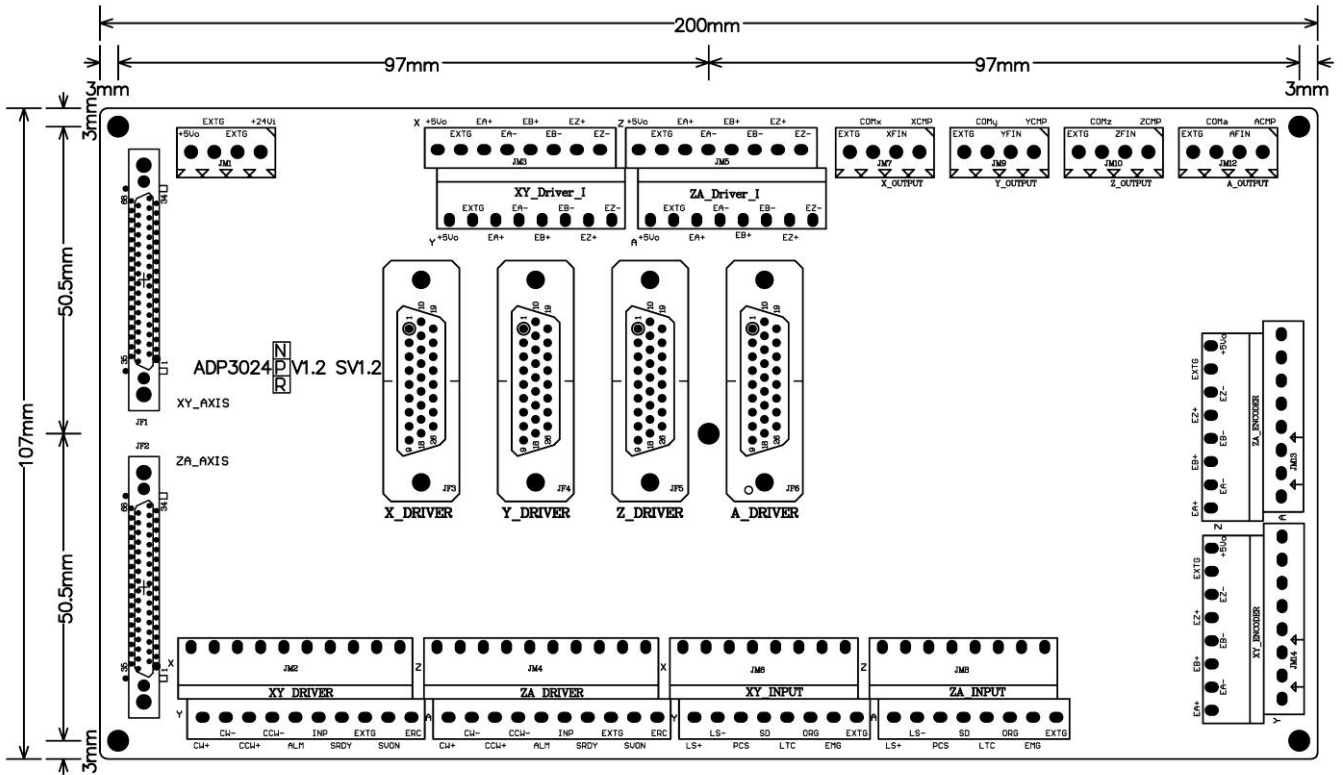

4.3 JS51050 for JM3 25PM Din rail mounted dummy wiring board

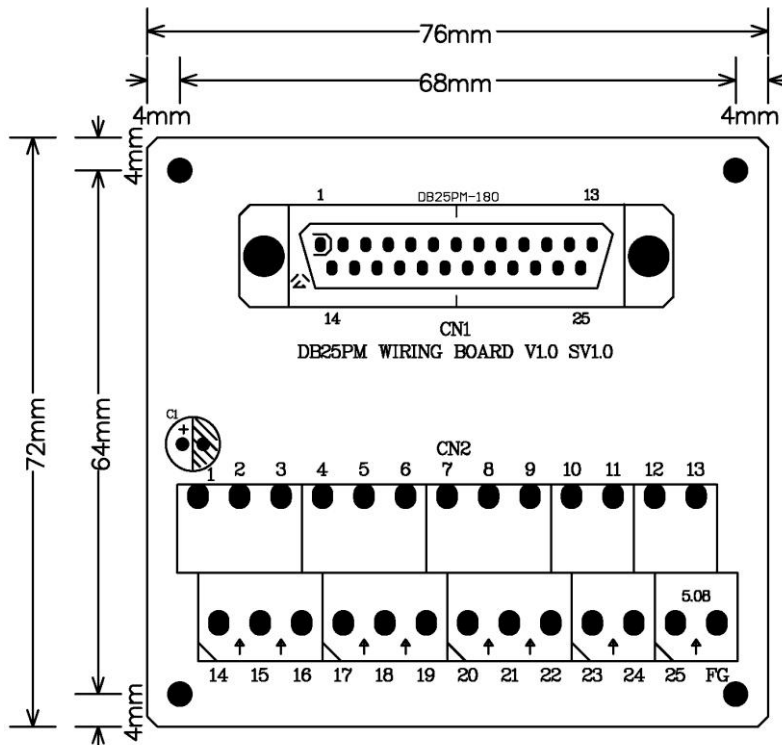

5. Pin definitions

5.1 JF1,JF2 Assignment / Definitions

		JF2 / JF1			
(X/Z)	LS+	1	35	LS-	(X/Z)
(X/Z)	SD	2	36	HOME	(X/Z)
(X/Z)	PCS	3	37	LTC	(X/Z)
(X/Z)	FIN	4	38	CMP	(X/Z)
(X/Z)	EA+	5	39	EA-	(X/Z)
(X/Z)	EB+	6	40	EB-	(X/Z)
(X/Z)	EZ+	7	41	EZ-	(X/Z)
(X/Z)	CW+	8	42	CW-	(X/Z)
(X/Z)	CCW+	9	43	CCW-	(X/Z)
(X/Z)	INP	10	44	SRDY	(X/Z)
(X/Z)	ALM	11	45	SVON	(X/Z)
(X/Z)	ERC	12	46	LS+	(Y/A)
(Y/A)	LS-	13	47	SD	(Y/A)
(Y/A)	HOME	14	48	PCS	(Y/A)
(Y/A)	LTC	15	49	FIN	(Y/A)
(Y/A)	CMP	16	50	EA+	(Y/A)
(Y/A)	EA-	17	51	EB+	(Y/A)
(Y/A)	EB-	18	52	EZ+	(Y/A)
(Y/A)	EZ-	19	53	CW+	(Y/A)
(Y/A)	CW-	20	54	CCW+	(Y/A)
(Y/A)	CCW-	21	55	INP	(Y/A)
(Y/A)	SRDY	22	56	ALM	(Y/A)
(Y/A)	SVON	23	57	ERC	(Y/A)
	NC	24	58	NC	
	NC	25	59	NC	
	NC	26	60	NC	
	NC	27	61	NC	
	NC	28	62	NC	
	NC	29	63	NC	
	EMG	30	64	EXTG	
	NC	31	65	NC	
	EXTG	32	66	EXTG	
	+5Vin	33	67	+5Vin	
	+24Vin	34	68	+24Vin	

PIN	I/O	Descriptions	PIN	I/O	Descriptions
1	I	Z/X_LS+(EL+) Positive over travel LS(EL) of Z/X axis	35	I	Z/X_LS-(EL-) Negative over travel LS(EL) of Z/X axis
2	I	Z/X_SD Slowdown LS(EL) of Z/X axis	36	I	Z/X_HOME(ORG) Home(ORG) LS(EL) of Z/X axis
3	I	Z/X_PCS Position change start signal of Z/X axis	37	I	Z/X_LTC Latch counter trigger of Z/X axis
4	O	Z/X_FIN General purpose output of Z/X axis	38	O	Z/X_CMP General out or compare out of Z/X axis
5	I	Z/X_EA+ Encoder phase A+ feedback of Z/X axis	39	I	Z/X_EA- Encoder phase A- feedback of Z/X axis
6	I	Z/X_EB+ Encoder phase B+ feedback of Z/X axis	40	I	Z/X_EB- Encoder phase B- feedback of Z/X axis
7	I	Z/X_EZ+ Encoder phase Z+ feedback of Z/X axis	41	I	Z/X_EZ- Encoder phase Z- feedback of Z/X axis
8	O	Z/X_CW+ CW+ or PULSE+ of Z/X axis	42	O	Z/X_CW- CW- or PULSE- of Z/X axis
9	O	Z/X_CCW+ CCW+ or DIR+ of Z/X axis	43	O	Z/X_CCW- CCW- or DIR- of Z/X axis
10	I	Z/X_INP General I/p of Z/X axis	44	I	Z/X_SRDY Servo Ready signal of Z/X axis
11	I	Z/XALM ALARM I/p of Z/X axis	45	O	XSVON -- Servo on of X axis
12	O	Z/X_ERC Output for resetting error counter of Z/X axis	46	I	A/Y_LS+(EL+) Positive over travel LS(EL) of A/Y axis
13	I	A/YLS-(EL-) Negative over travel LS(EL) of A/Y axis	47	I	A/Y_SD Slowdown LS(EL) of A/Y axis
14	I	A/Y_HOME(ORG) Home(ORG) LS(EL) of A/Y axis	48	I	A/Y_PCS Position change start signal of A/Y axis
15	I	A/Y_LTC Latch counter trigger of A/Y axis	49	O	A/Y_FIN General purpose output of A/Y axis
16	O	A/Y_CMP General out or compare out of A/Y axis	50	I	A/Y_EA+ Encoder phase A+ feedback of A/Y axis
17	I	A/Y_EA- Encoder phase A- feedback of A/Y axis	51	I	A/Y_EB+ Encoder phase B+ feedback of A/Y axis
18	I	A/Y_EB- Encoder phase B- feedback of A/Y axis	52	I	A/Y_EZ+ Encoder phase Z+ feedback of A/Y axis
19	I	A/Y_EZ- Encoder phase Z- feedback of A/Y axis	53	O	A/YCW+ CW+ or PULSE+ of A/Y axis
20	O	A/Y_CW- CW- or PULSE- of A/Y axis	54	O	A/Y_CCW+ CCW+ or DIR+ of A/Y axis
21	O	A/Y_CCW- CCW- or DIR- of A/Y axis	55	I	A/Y_INP General I/p of A/Y axis
22	I	A/Y_SRDY Servo Ready signal of A/Y axis	56	I	A/Y_ALM ALARM I/p of A/Y axis
23	O	A/YSVON Servo on of A/Y axis	57	O	A/Y_ERC Output for resetting error counter of A/Y axis
24 29		NC	58 63		NC
30	I	EMG Emergency stop, stop all axes	64		EXTG Common for external power (+24V and +5V)
31		NC	65		NC
32		EXTG Common for external power (+24V and +5V)	66		EXTG Common for external power (+24V and +5V)
33	O	+5V DC5V power output for external device	67	O	+5V DC5V power output for external device
34	I	+24V External DC24V power input	68	I	+24V External DC24V power input

5.2 JM1, JM2 Assignment / Definitions

PIN	Description
1	CSTA: common start I/O
2	CSTP: common stop I/O
3	GND

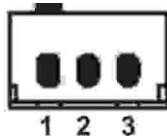

Note: Connect CSTA low to start motion from external.

Connect CSTP low to emergency stop motion from external.

5.3 JM3 Assignment / Definitions

PIN	Description		PIN	Description
1	+5Vout_PC +5V from PC	+5Vout_PC	14	+5Vout_PC +5V from PC
2	PA1 Pulse handler1 A phase input	PA1	15	PB1 Pulse handler1 B phase input
3	PA2 Pulse handler2 A phase input	PA2	16	PB2 Pulse handler2 B phase input
4	GND	GND	17	GND
5	PA3 Pulse handler3 A phase input	PA3	18	PB3 Pulse handler3 B phase input
6	PA4 Pulse handler4 A phase input	PA4	19	PB4 Pulse handler4 B phase input
7	GND	GND	20	GND
8	+5Vout_PC +5V from PC	+5Vout_PC	21	+5Vout_PC +5V from PC
9	IO0 TTL I/O bit0	IO0	22	IO1 TTL I/O bit1
10	IO 2 TTL I/O bit2	IO2	23	IO 3 TTL I/O bit3
11	IO 4 TTL I/O bit4	IO4	24	IO 5 TTL I/O bit5
12	IO 6 TTL I/O bit6	IO6	25	IO 7 TTL I/O bit7
13	GND	GND		



6. I/O interface diagram

6.1 JF1/2 ADP3024DIN

6.1.1 Input diagram

Type1 input:

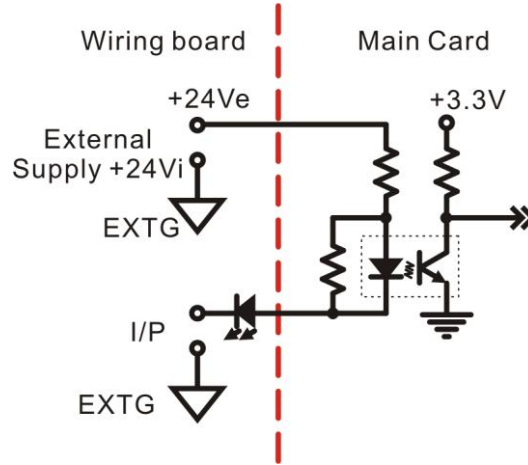

For input: LS+(EL+), LS-(EL-), HOME(ORG), SD,PCS,EMG, LTC

Type2 input:

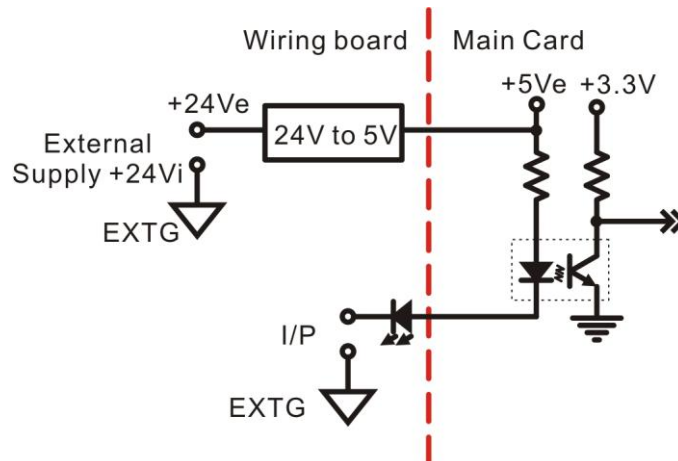

For input: INP,SRDY,ALM

Type3 input:

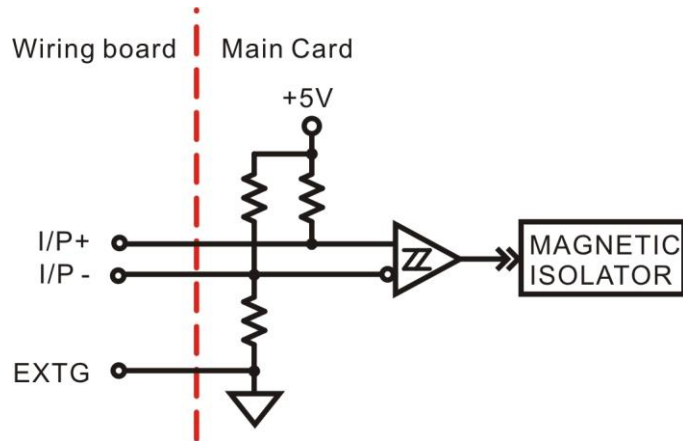

For encoder feedback input : A+/-,B+/-,Z/-

6.1.2 Output diagram

Type1 output:

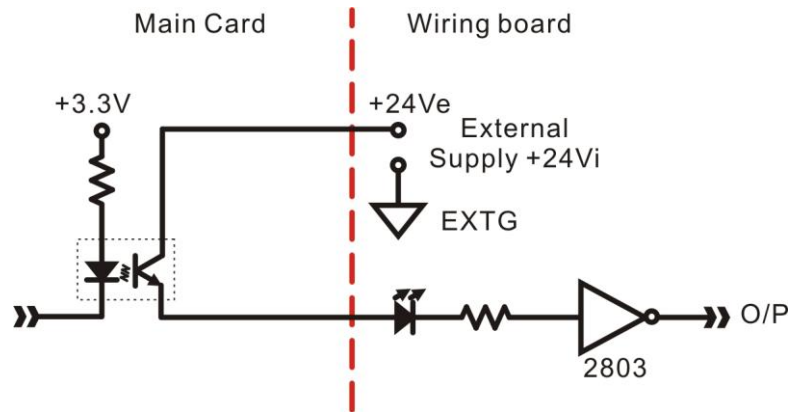

For SVON, ERC

Type2 output:

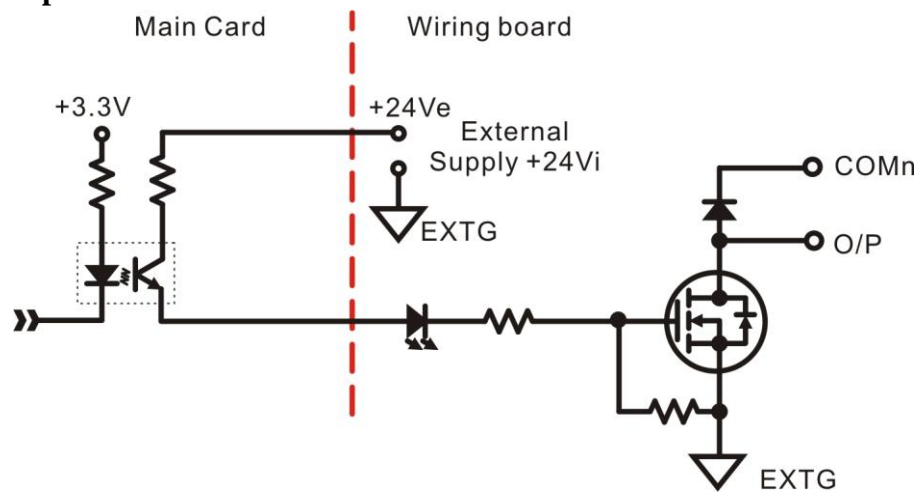

FIN,CMP(NMOS)

Type3 output:

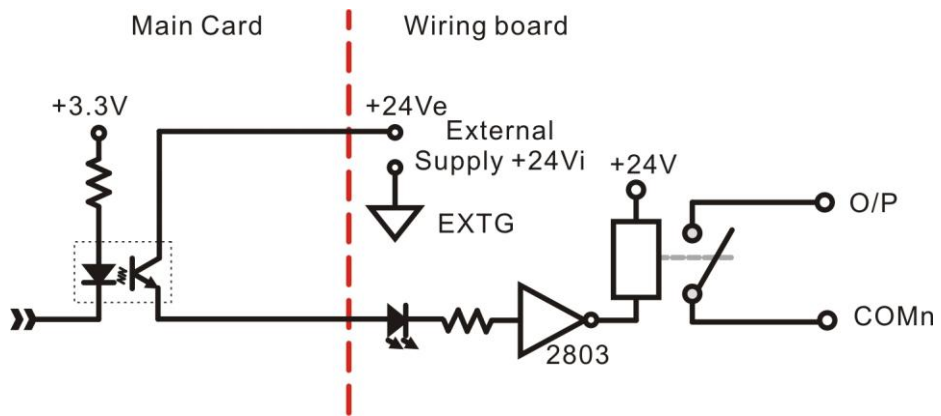

FIN,CMP(Relay)

Type4 output:

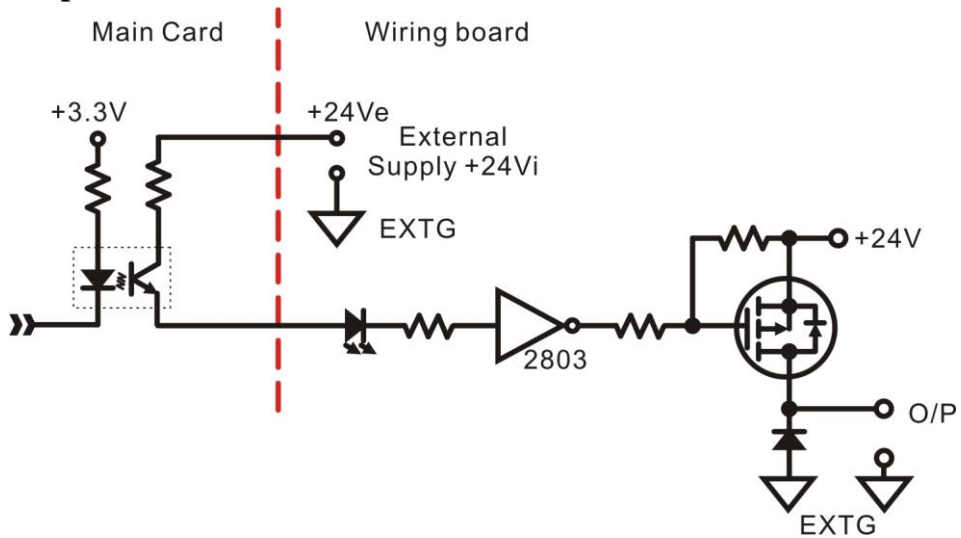

FIN,CMP(PMOS)

Type5 output:

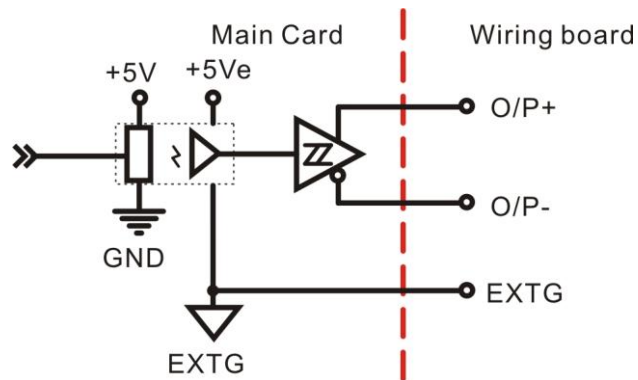

For motion control pulse output : CW,CCW

6.2 JM3 JS51050

Type 1 Input:

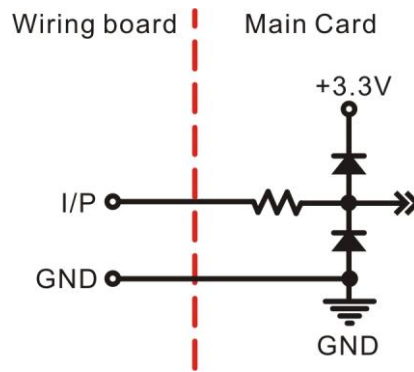

For Pulse Handler Input : PA,PB

Type 2 TTL I/O:

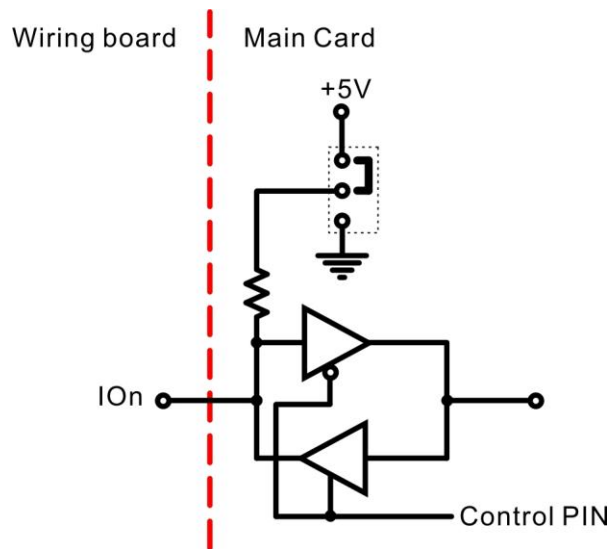

For byte-programmable TTL I/O IO₀ ~ IO₇ to configured as pull high or pull low. JP1 are used for output state of power on. (refer 8.3 JP1 Jumper setting)

7. External wiring diagram

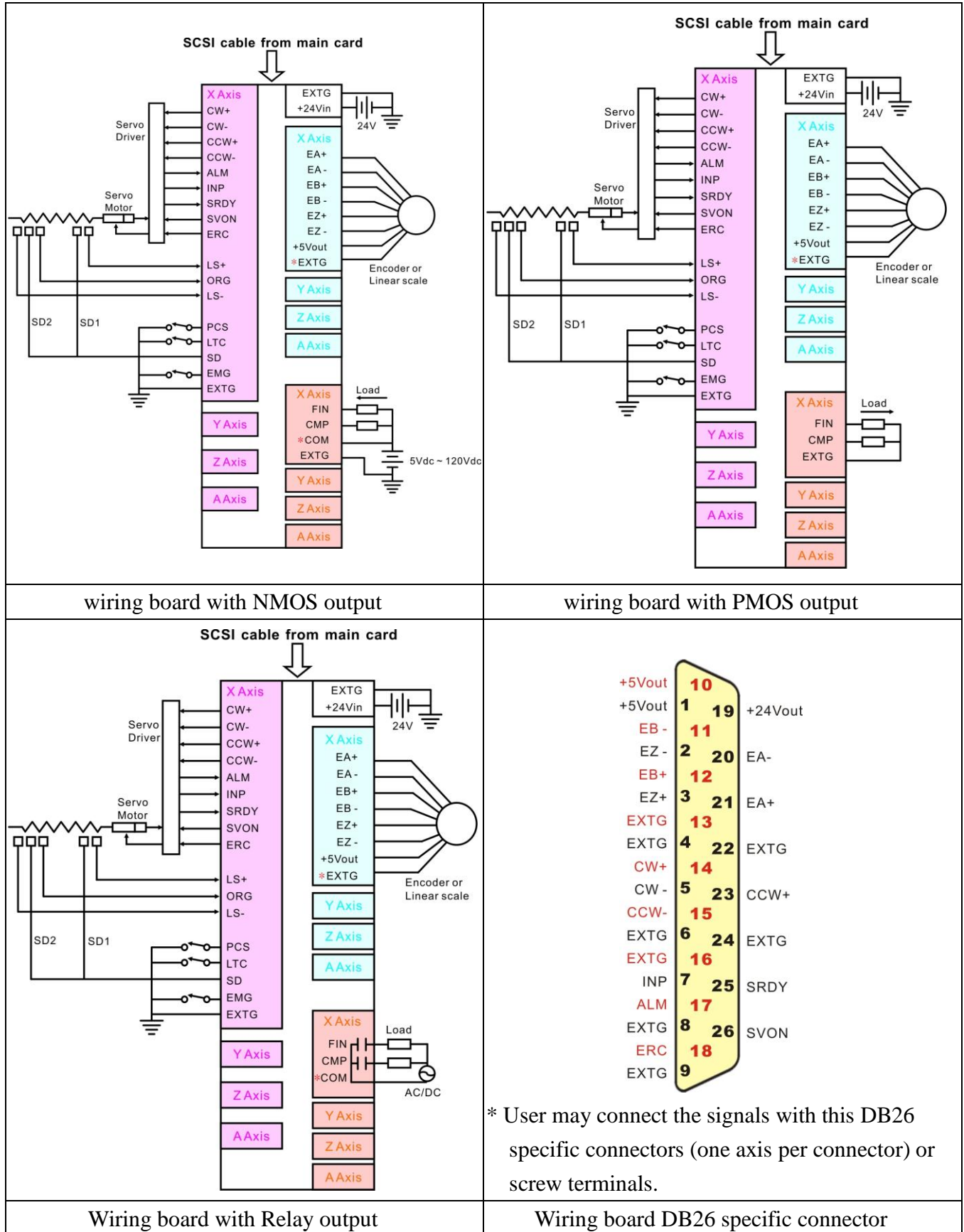

*Differential signals needs connect EXTG as common.

*COM connect to power supply as free-wheel path to avoid high voltage induced by inductive load.

8. Hardware settings

8.1 Card ID setting

Since PCI cards have plug and play function, the card ID is required for programmer to identify which card he/she will control without knowing the physical address assigned by the Windows. A 4 bits ROTARY switch (select from 0 to 0xF) for extinguishing the 16 identical card.

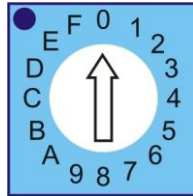

8.2 Polarity setting for over-travel limit switch

For different applications maybe you have different considerations, the polarity of over-travel limit switch can be set by on card Dip switch to meet your requirement.

Default : A, Z, Y, X axis are in negative polarity , the DIP switch set as follows.

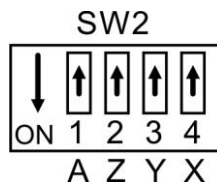

Example : A, Z axis are in negative polarity and Y, X axis polarity are positive, the DIP switch set as follows.

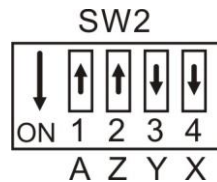

8.3 JP1 Jumper setting

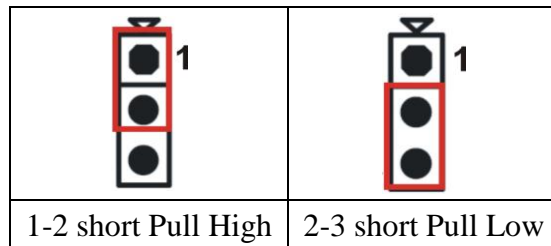

Jumper JP1 is used for the TTL output default state, if you disable the TTL port or at computer start-up period, the default state will be output. Select the one to match with the succeeding circuit.

9. Applications

- Precision positioning control
- Precision speed control
- Contouring control
- X-Y table control
- Rotary machine control
- Robotic control
- Biotech sampling and handling
- Any combined control of servo and stepping motors

10. Wiring diagram examples

10.1 The wiring diagram for MPC3034A wiring board to panasonic MINAS-A driver

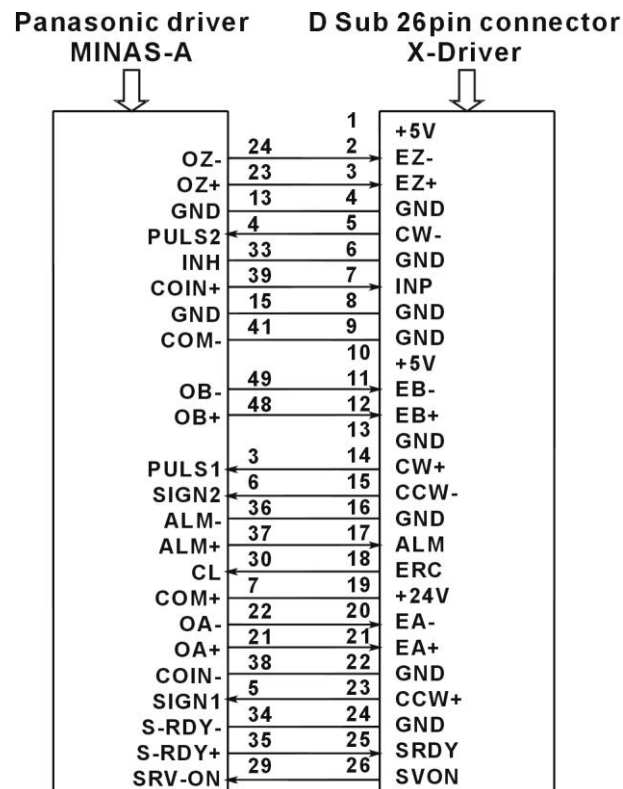

10.2 The wiring diagram for MPC3034A wiring board to panasonic MINAS MSD*** driver

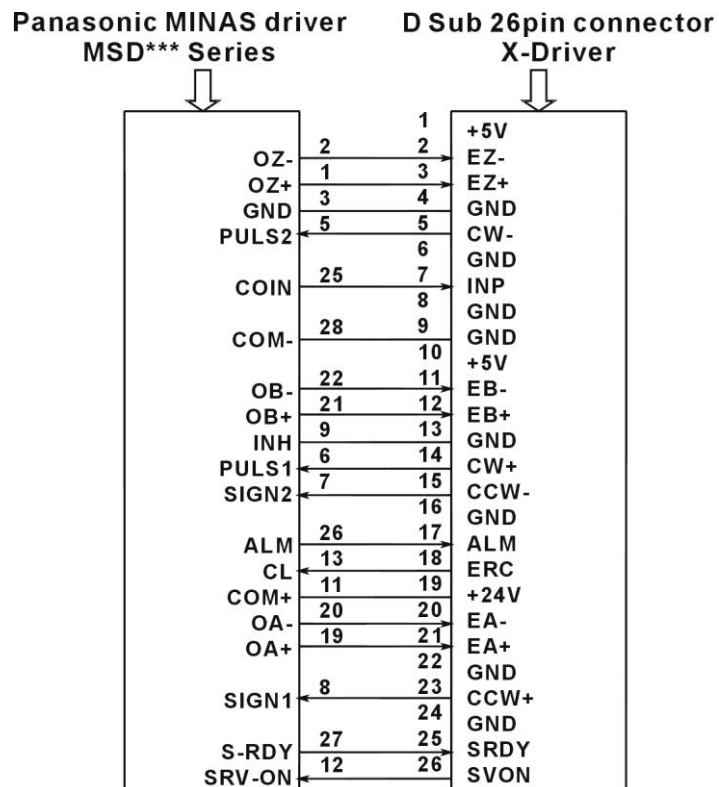

10.3 The wiring diagram for MPC3034A wiring board to ESD servo driver

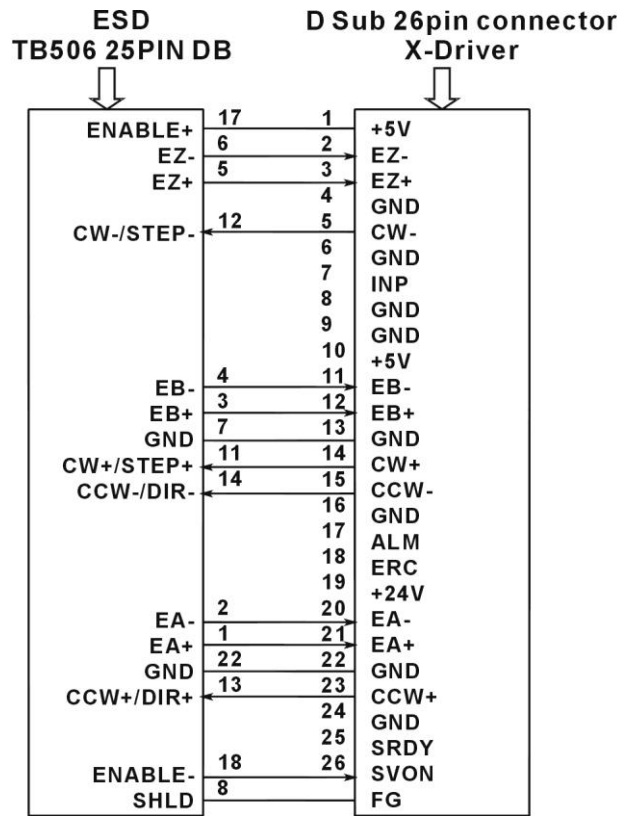

10.4 The wiring diagram for MPC3034A wiring board to Moda servo driver

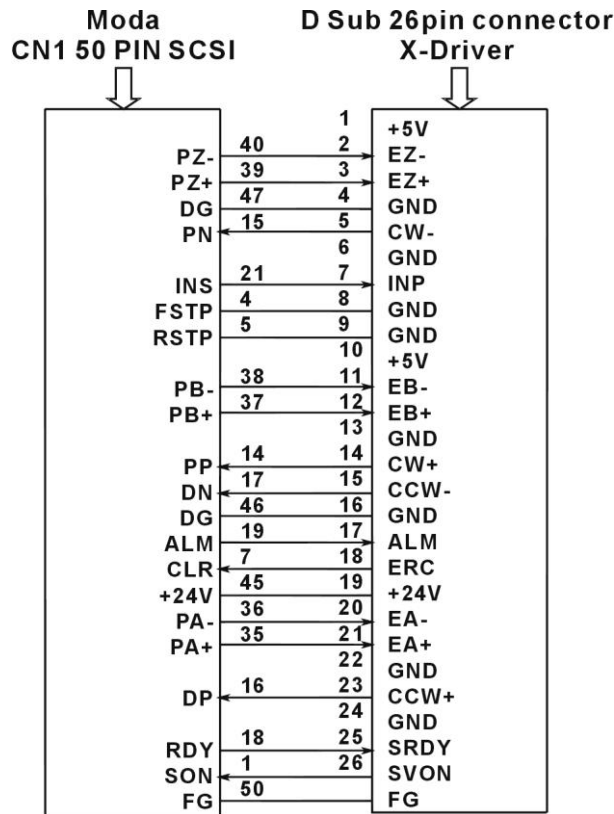

10.5 The wiring diagram for MPC3034A wiring board to YASKAWA servo driver

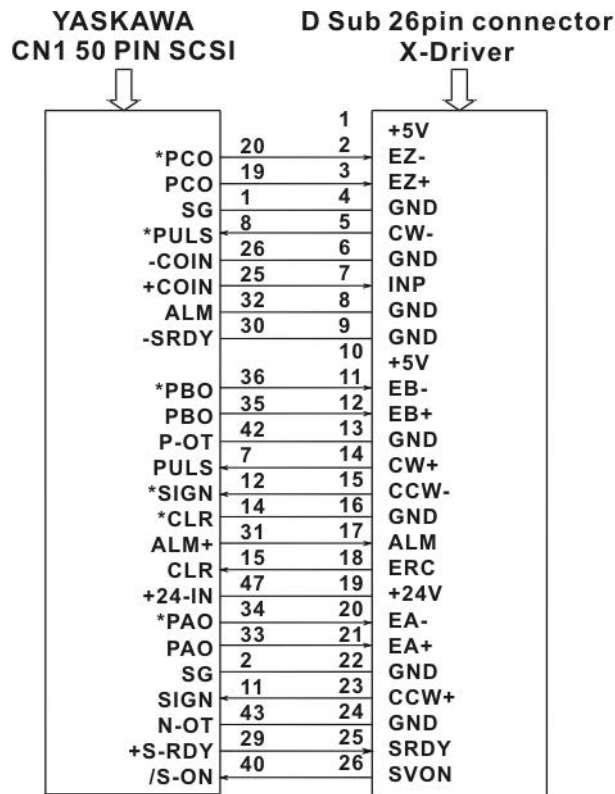

10.6 The wiring diagram for MPC3034A wiring board to Mokon / YPV servo driver

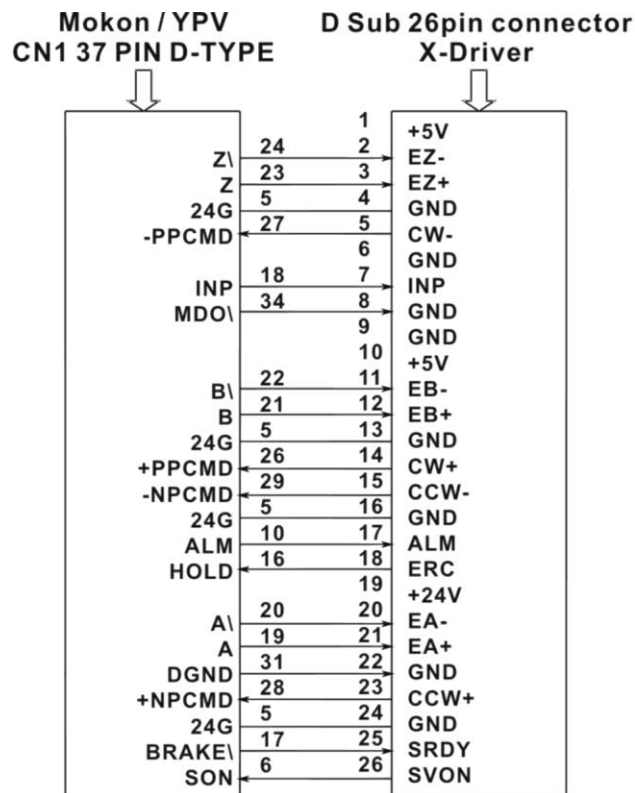

10.7 The wiring diagram for MPC3034A wiring board to Mokon / YJD servo driver

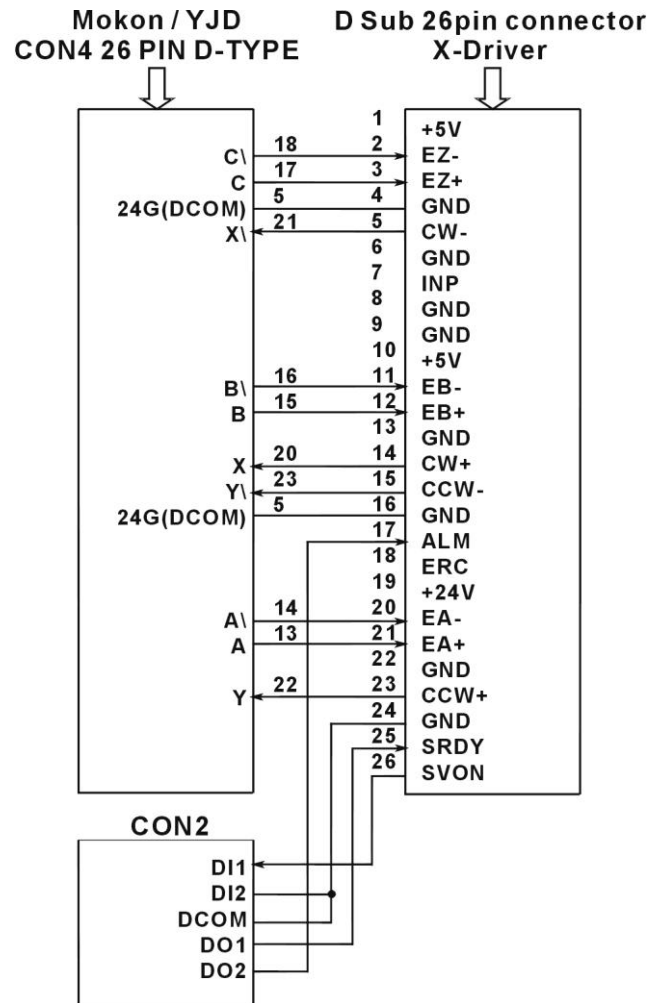

10.8 The wiring diagram for MPC3034A wiring board to MITSUBISHI J2-SUPER servo driver

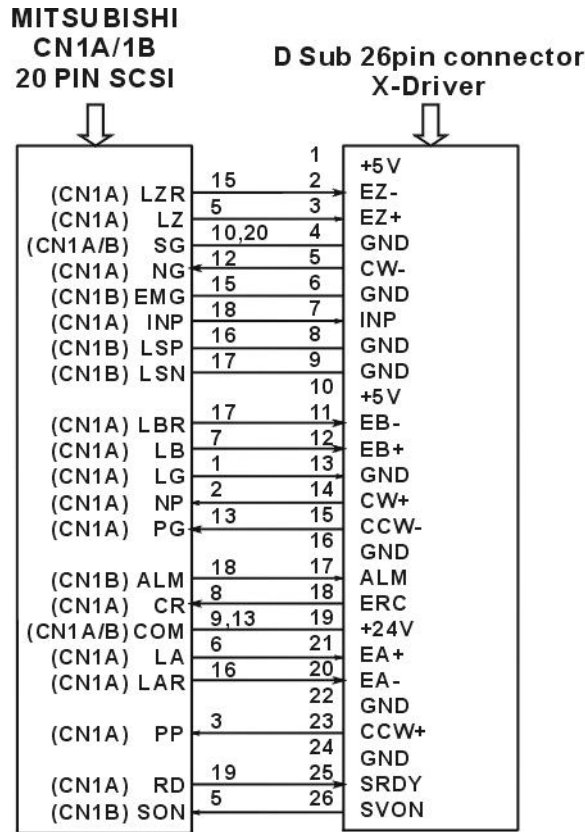

10.9 The wiring diagram for MPC3034A wiring board to YAMAHA SRCP servo driver

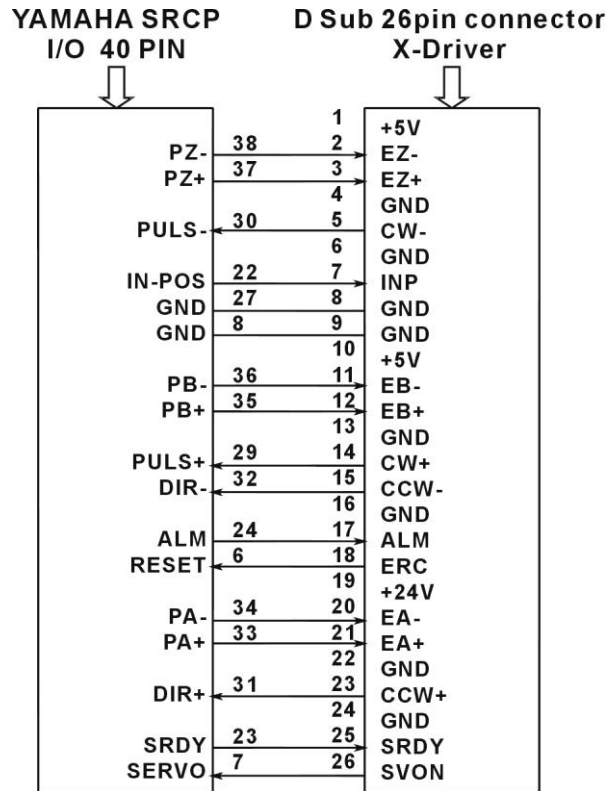

10.10 The wiring diagram for MPC3034A wiring board to Delta ASDA-B servo driver

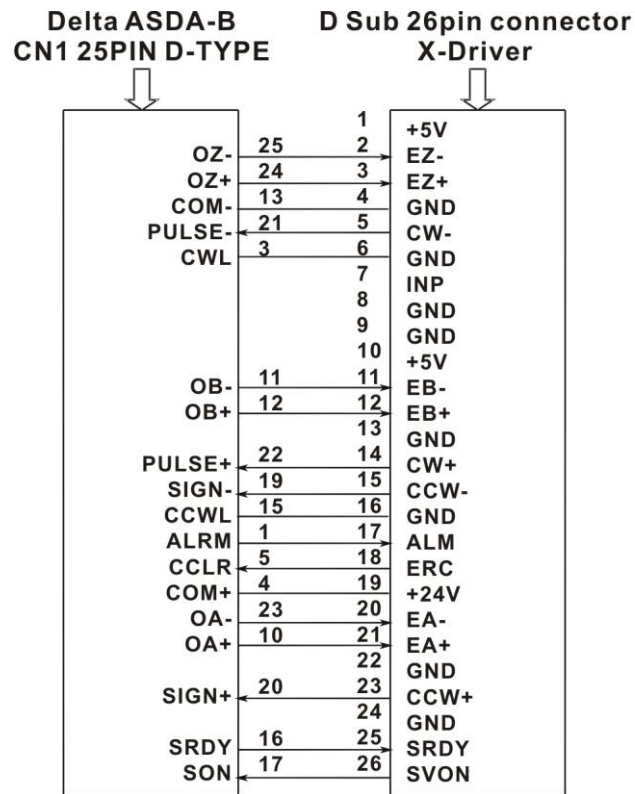

10.11 The wiring diagram for MPC3034A wiring board to Delta ASDA-B2 servo driver

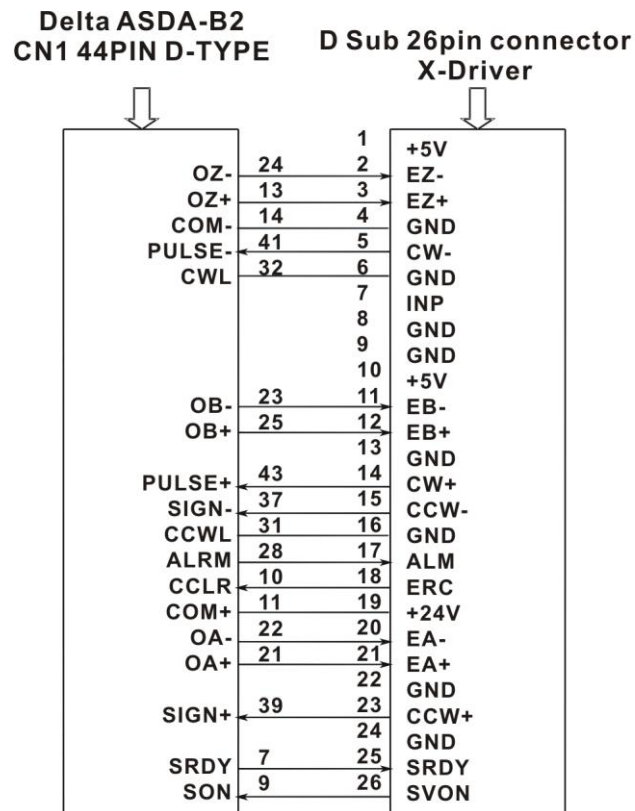

11. Ordering information

<u>PRODUCT</u>	<u>DESCRIPTIONS</u>
MPC3034A	4-axis motion control card for servo/step motor control with advanced functions
ADP3024DIN(N)	DIN rail mounted wiring board matched MPC3024/3028/3034/3035/3035L/3024A/3028A/3034A/3035A/3035AL, General output: 8 power NMOS
ADP3024DIN(P)	DIN rail mounted wiring board matched MPC3024/3028/3034/3035/3035L/3024A/3028A/3034A/3035A/3035AL, General output: 8 power PMOS
ADP3024DIN(R)	DIN rail mounted wiring board matched MPC3024/3028/3034/3035/3035L/3024A/3028A/3034A/3035A/3035AL, General output: 8 relays
JS51050	DIN rail mounted dummy wiring board for 25-pin D-Type male connector (for JM3)
FVC01	F to V Module
M266868151	68-pin mini-SCSI cable 1.5M (2 axes control signal granted in one cable)
M2668683011	68-pin mini-SCSI cable 3.0M (2 axes control signal granted in one cable)
M270325X4	D type 25p male-female cable 1.5M
M270325X4S	D type 25p male-female cable 1.5M, shielding
M270325X0	D type 25p male-female cable 3.0M
M270325X0S	D type 25p male-female cable 3.0M, shielding
SM23404	Extension kit for JM3 (bracket and flat cable for 25p D-type connector)